

	6	7PC	7	8PC	10
System Frequency (f _{CK})	166 MHz	143 MHz	143 MHz	125 MHz	100MHz
Clock Cycle Time (t _{CK3})	6 ns	7 ns	7 ns	8 ns	10 ns
Clock Access Time (t _{AC3}) $\overline{\text{CAS}}$ Latency = 3	5.4 ns	5.4 ns	5.4 ns	6 ns	7 ns
Clock Access Time (t _{AC2}) CAS Latency = 2	5.4 ns	5.4 ns	6 ns	6 ns	8 ns
Clock Access Time (t _{AC1}) CAS Latency = 1	19 ns	19 ns	19 ns	19 ns	22 ns

Features

- 4 banks x 2Mbit x 16 organization
- High speed data transfer rates up to 166 MHz
- Full Synchronous Dynamic RAM, with all signals referenced to clock rising edge
- Single Pulsed $\overline{\text{RAS}}$ Interface
- Data Mask for Read/Write Control
- Four Banks controlled by BA0 & BA1
- Programmable $\overline{\text{CAS}}$ Latency: 1, 2, 3
- Programmable Wrap Sequence: Sequential or Interleave
- Programmable Burst Length:
 1, 2, 4, 8, Full page for Sequential Type
 1, 2, 4, 8 for Interleave Type
- Multiple Burst Read with Single Write Operation
- Automatic and Controlled Precharge Command
- Random Column Address every CLK (1-N Rule)
- Power Down Mode and Clock Suspend Mode
- Deep Power Mode
- Auto Refresh and Self Refresh
- Refresh Interval: 4096 cycles/64 ms
- Available in 54-ball FBGA, with 9x6 ball array with 3 depopulated rows, 9x8 mm and 54 pin TSOP II
- VDD=2.5V, VDDQ=1.8V
- Programmable Power Reduction Feature by partial array activation during Self-Refresh
- Operating Temperature Range
 Commercial (0°C to 70°C)
 Extended (-25°C to +85°C)

Device Usage Chart

Operating Temperature Range	Package Outline	Access Time (ns)					Temperature Mark
	T/B	6	7PC	7	8PC	10	
0°C to 70°C	•	•	•	•	•	•	Commercial
-25°C to 85°C	•	•	•	•	•	•	Extended

Description	Pkg.	Pin Count
BGA	B	54

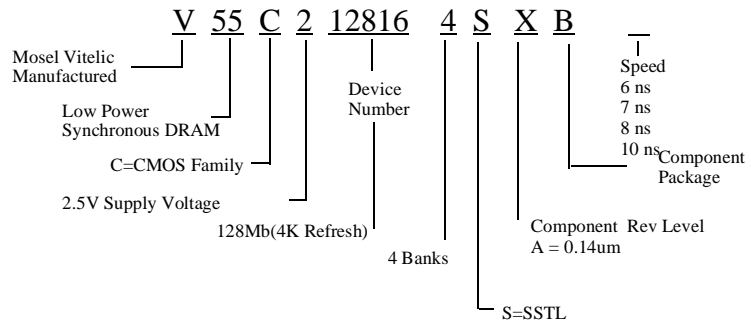

Pin Configuration for x16 devices:

1	2	3		7	8	9
VSS	DQ15	VSSQ	A	VDDQ	DQ0	VDD
DQ14	DQ13	VDDQ	B	VSSQ	DQ2	DQ1
DQ12	DQ11	VSSQ	C	VDDQ	DQ4	DQ3
DQ10	DQ9	VDDQ	D	VSSQ	DQ6	DQ5
DQ8	NC	VSS	E	VDD	LDQM	DQ7
UDQM	CLK	CKE	F	$\overline{\text{CAS}}$	$\overline{\text{RAS}}$	$\overline{\text{WE}}$
NC	A11	A9	G	BA0	BA1	$\overline{\text{CS}}$
A8	A7	A6	H	A0	A1	A10
VSS	A5	A4	J	A3	A2	VDD

< Top-view >

Description	Pkg.	Pin Count
TSOP-II	T	54

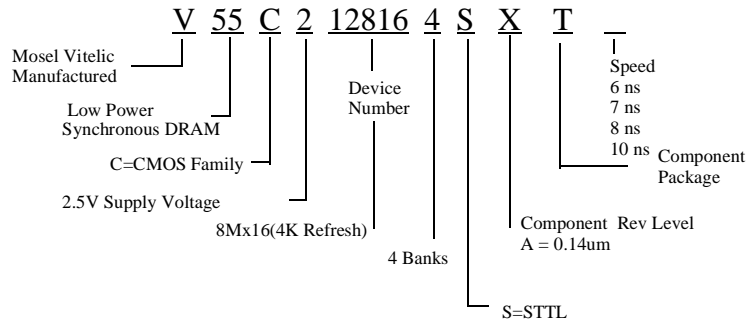

**54 Pin Plastic TSOP-II
PIN CONFIGURATION
Top View**

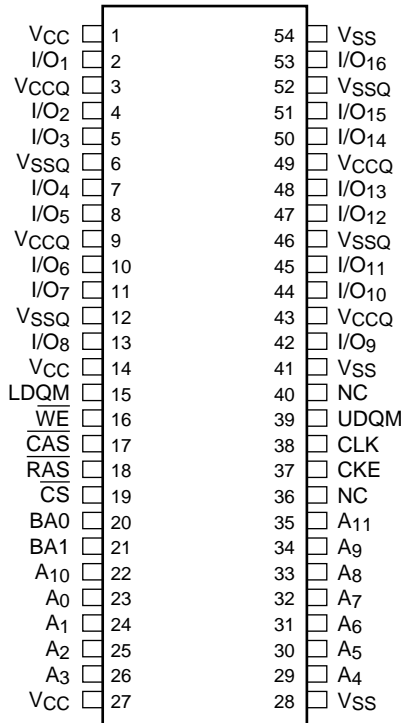

Pin Names

CLK	Clock Input
CKE	Clock Enable
\overline{CS}	Chip Select
\overline{RAS}	Row Address Strobe
\overline{CAS}	Column Address Strobe
\overline{WE}	Write Enable
A ₀ -A ₁₁	Address Inputs
BA0, BA1	Bank Select
I/O ₁ -I/O ₁₆	Data Input/Output
LDQM, UDQM	Data Mask
V _{CC}	Power (+2.5V)
V _{SS}	Ground
V _{CCQ}	Power for I/O's (+1.8V)
V _{SSQ}	Ground for I/O's
NC	Not connected

Description

The V55C2128164V(T/B) is a four bank Synchronous DRAM organized as 4 banks x 2Mbit x 16. The V55C2128164V(T/B) achieves high speed data transfer rates up to 166 MHz by employing a chip architecture that prefetches multiple bits and then synchronizes the output data to a system clock

All of the control, address, data input and output circuits are synchronized with the positive edge of an externally supplied clock.

Operating the four memory banks in an interleaved fashion allows random access operation to occur at higher rate than is possible with standard DRAMs. A sequential and gapless data rate of up to 166 MHz is possible depending on burst length, CAS latency and speed grade of the device.

Signal Pin Description

Pin	Type	Signal	Polarity	Function
CLK	Input	Pulse	Positive Edge	The system clock input. All of the SDRAM inputs are sampled on the rising edge of the clock.
CKE	Input	Level	Active High	Activates the CLK signal when high and deactivates the CLK signal when low, thereby initiates either the Power Down mode or the Self Refresh mode.
\overline{CS}	Input	Pulse	Active Low	\overline{CS} enables the command decoder when low and disables the command decoder when high. When the command decoder is disabled, new commands are ignored but previous operations continue.
\overline{RAS} , \overline{CAS} , \overline{WE}	Input	Pulse	Active Low	When sampled at the positive rising edge of the clock, \overline{CAS} , \overline{RAS} , and \overline{WE} define the command to be executed by the SDRAM.
A0 - A11	Input	Level	—	During a Bank Activate command cycle, A0-A11 defines the row address (RA0-RA11) when sampled at the rising clock edge. During a Read or Write command cycle, A0-An defines the column address (CA0-CAn) when sampled at the rising clock edge. CAn depends from the SDRAM organization: • 8M x 16 SDRAM CA0–CA8. In addition to the column address, A10(=AP) is used to invoke autoprecharge operation at the end of the burst read or write cycle. If A10 is high, autoprecharge is selected and BA0, BA1 defines the bank to be precharged. If A10 is low, autoprecharge is disabled. During a Precharge command cycle, A10(=AP) is used in conjunction with BA0 and BA1 to control which bank(s) to precharge. If A10 is high, all four banks will BA0 and BA1 are used to define which bank to precharge.
BA0, BA1	Input	Level	—	Selects which bank is to be active.
DQx	Input Output	Level	—	Data Input/Output pins operate in the same manner as on conventional DRAMs.
LDQM UDQM	Input	Pulse	Active High	The Data Input/Output mask places the DQ buffers in a high impedance state when sampled high. In Read mode, DQM has a latency of two clock cycles and controls the output buffers like an output enable. In Write mode, DQM has a latency of zero and operates as a word mask by allowing input data to be written if it is low but blocks the write operation if DQM is high.
VCC, VSS	Supply			Power and ground for the input buffers and the core logic.
VCCQ VSSQ	Supply	—	—	Isolated power supply and ground for the output buffers to provide improved noise immunity.

Operation Definition

All of SDRAM operations are defined by states of control signals \overline{CS} , \overline{RAS} , \overline{CAS} , \overline{WE} , and DQM at the positive edge of the clock. The following list shows the thruth table for the operation commands.

Operation	Device State	CKE n-1	CKE n	\overline{CS}	\overline{RAS}	\overline{CAS}	\overline{WE}	DQM	A0-9, A11	A10	BS0 BS1
Row Activate	Idle ³	H	X	L	L	H	H	X	V	V	V
Read	Active ³	H	X	L	H	L	H	X	V	L	V
Read w/Autoprecharge	Active ³	H	X	L	H	L	H	X	V	H	V
Write	Active ³	H	X	L	H	L	L	X	V	L	V
Write with Autoprecharge	Active ³	H	X	L	H	L	L	X	V	H	V
Row Precharge	Any	H	X	L	L	H	L	X	X	L	V
Precharge All	Any	H	X	L	L	H	L	X	X	H	X
Mode Register Set	Idle	H	X	L	L	L	L	X	V	V	V
No Operation	Any	H	X	L	H	H	H	X	X	X	X
Device Deselect	Any	H	X	H	X	X	X	X	X	X	X
Auto Refresh	Idle	H	H	L	L	L	H	X	X	X	X
Self Refresh Entry	Idle	H	L	L	L	L	H	X	X	X	X
Self Refresh Exit	Idle (Self Refr.)	L	H	H	X	X	X	X	X	X	X
				L	H	H	X				
Power Down Entry	Idle Active ⁴	H	L	H	X	X	X	X	X	X	X
				L	H	H	X				
Power Down Exit	Any (Power Down)	L	H	H	X	X	X	X	X	X	X
				L	H	H	L				
Data Write/Output Enable	Active	H	X	X	X	X	X	L	X	X	X
Data Write/Output Disable	Active	H	X	X	X	X	X	H	X	X	X
Deep Pwoer Down Entry	Idle	H	L	L	H	H	L	H	X	X	X
Deep Pwoer Down Exit	Deep power-Down	L	H	X	X	X	X	H	X	X	X

Notes:

1. V = Valid , x = Don't Care, L = Low Level, H = High Level
2. CKE n signal is input level when commands are provided, CKE n-1 signal is input level one clock before the commands are provided.
3. These are state of bank designated by BS0, BS1 signals.
4. Power Down Mode can not entry in the burst cycle.
5. After Deep Power Down mode exit a full new initialization of memory device is mandatory

Power On and Initialization

The default power on state of the mode register is supplier specific and may be undefined. The following power on and initialization sequence guarantees the device is preconditioned to each users specific needs. Like a conventional DRAM, the Synchronous DRAM must be powered up and initialized in a predefined manner. During power on, all VCC and VCCQ pins must be built up simultaneously to the specified voltage when the input signals are held in the "NOP" state. The power on voltage must not exceed VCC+0.3V on any of the input pins or VCC supplies. The CLK signal must be started at the same time. After power on, an initial pause of 200 μ s is required followed by a precharge of both banks using the precharge command. To prevent data contention on the DQ bus during power on, it is required that the DQM and CKE pins be held high during the initial pause period. Once all banks have been precharged, the Mode Register and Low Power Mode Register Set Command must be issued to initialize the Mode Register. A minimum of two Auto Refresh cycles (CBR) are also required. These may be done before or after programming the Mode Register. Failure to follow these steps may lead to unpredictable start-up modes.

Programming the Mode Register

The Mode register designates the operation mode at the read or write cycle. This register is divided into 4 fields. A Burst Length Field to set the length of the burst, an Addressing Selection bit to program the column access sequence in a burst cycle (interleaved or sequential), a CAS Latency Field to set the access time at clock cycle and a Operation mode field to differentiate between normal operation (Burst read and burst Write) and a special Burst Read and Single Write mode. The mode set operation must be done before any activate command after the initial power up. Any content of the mode register can be altered by re-executing the mode set command. All banks must be in pre-charged state and CKE must be high at least one clock before the mode set operation. After the mode register is set, a Standby or NOP command is required. Low signals of RAS, CAS, and WE at the positive edge of the clock activate the mode set operation. Address input data at this timing defines pa-

rameters to be set as shown in the previous table.

Low Power Mode Register

The Low Power Mode Register controls functions beyond those controlled by the Mode Register. These additional functions are unique to the Low-Power DRAM and includes a Refresh Period field (TCR) for temperature compensated self-refresh and a Partial-Array Self-Refresh field (PAS). The PASR field is used to specify whether only one quarter (bank 0), one half (bank 0+1) or all banks of the SDRAM array are enabled. Disabled banks will not be refreshed in Self-Refresh mode and written data will be lost. When only bank 0 is selected, it's possible to partially select only half or more quarter of bank 0. The TCR field has four entries to set Refresh Period during self-refresh depending on the case temperature of the Low power RAM. It's required during the initialization sequence and can be modified when the part is idle.

Read and Write Operation

When RAS is low and both CAS and WE are high at the positive edge of the clock, a RAS cycle starts. According to address data, a word line of the selected bank is activated and all of sense amplifiers associated to the wordline are set. A CAS cycle is triggered by setting RAS high and CAS low at a clock timing after a necessary delay, t_{RCD} , from the RAS timing. WE is used to define either a read (WE = H) or a write (WE = L) at this stage.

SDRAM provides a wide variety of fast access modes. In a single CAS cycle, serial data read or write operations are allowed at up to a 125 MHz data rate. The numbers of serial data bits are the burst length programmed at the mode set operation, i.e., one of 1, 2, 4, 8. Column addresses are segmented by the burst length and serial data accesses are done within this boundary. The first column address to be accessed is supplied at the CAS timing and the subsequent addresses are generated automatically by the programmed burst length and its sequence. For example, in a burst length of 8 with interleave sequence, if the first address is '2', then the rest of the burst sequence is 3, 0, 1, 6, 7, 4, and 5.

Address Input for Mode Set (Mode Register Operation)

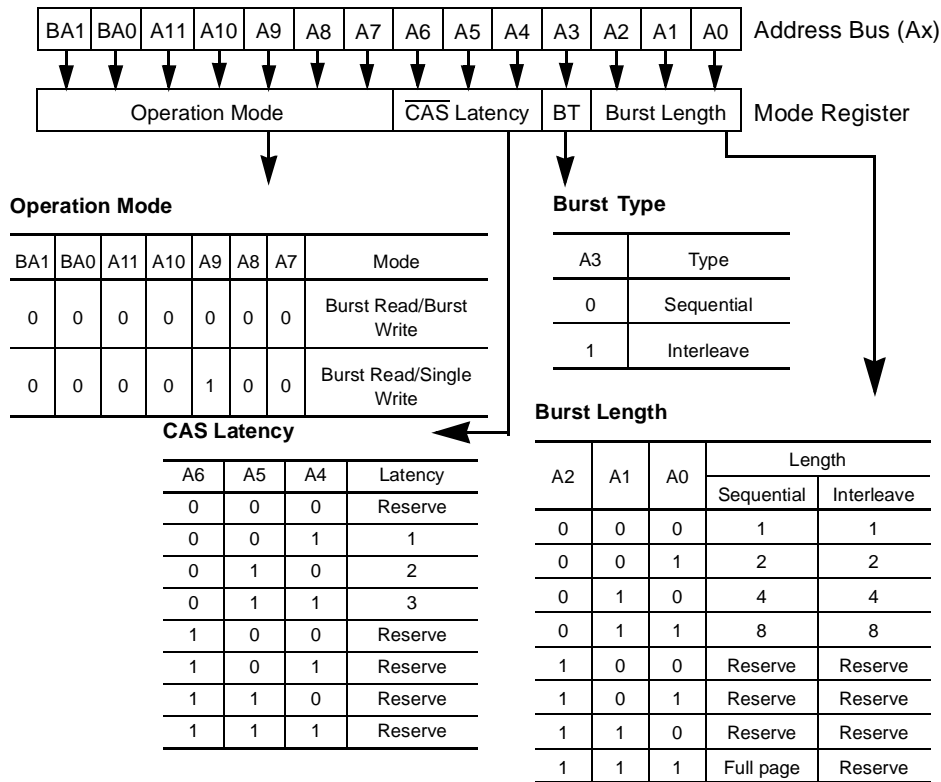

Similar to the page mode of conventional DRAM's, burst read or write accesses on any column address are possible once the RAS cycle latches the sense amplifiers. The maximum t_{RAS} or the refresh interval time limits the number of random column accesses. A new burst access can be done even before the previous burst ends. The interrupt operation at every clock cycles is supported. When the previous burst is interrupted, the remaining addresses are overridden by the new address with the full burst length. An interrupt which accompanies

with an operation change from a read to a write is possible by exploiting DQM to avoid bus contention. When two or more banks are activated sequentially, interleaved bank read or write operations are possible. With the programmed burst length, alternate access and precharge operations on two or more banks can realize fast serial data access modes among many different pages. Once two or more banks are activated, column to column interleave operation can be done between different pages.

Low Power Mode Register Table

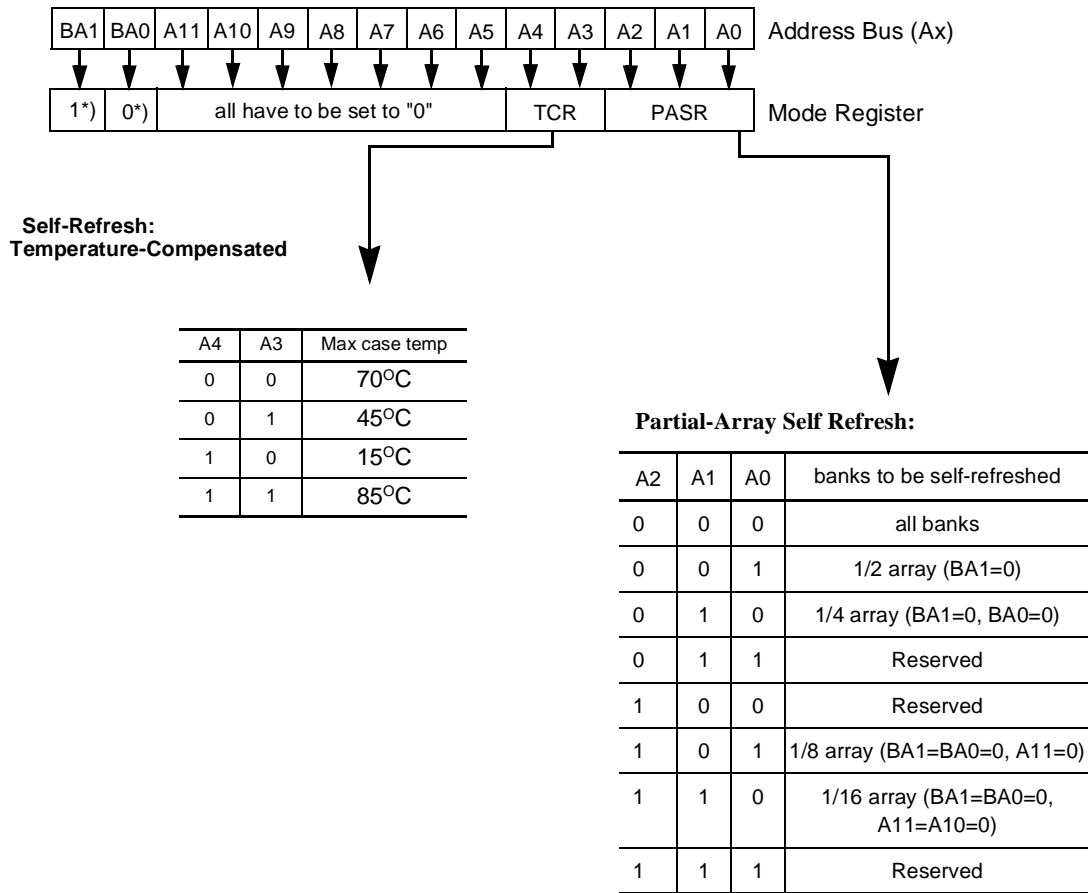

*)BA1 and BA0 must be 1, 0 to select the Extended Mode Register (Vs. the Mode Register)

The Low Power Mode Register must be set during the initialization sequence. Once the device is operational, the Low Power Mode Register set can be issued anytime when the part is idle.

Burst Length and Sequence:

Burst Length	Starting Address (A2 A1 A0)	Sequential Burst Addressing (decimal)	Interleave Burst Addressing (decimal)
2	xx0	0, 1	0, 1
	xx1	1, 0	1, 0
4	x00	0, 1, 2, 3	0, 1, 2, 3
	x01	1, 2, 3, 0	1, 0, 3, 2
	x10	2, 3, 0, 1	2, 3, 0, 1
	x11	3, 0, 1, 2	3, 2, 1, 0
8	000	0 1 2 3 4 5 6 7	0 1 2 3 4 5 6 7
	001	1 2 3 4 5 6 7 0	1 0 3 2 5 4 7 6
	010	2 3 4 5 6 7 0 1	2 3 0 1 6 7 4 5
	011	3 4 5 6 7 0 1 2	3 2 1 0 7 6 5 4
	100	4 5 6 7 0 1 2 3	4 5 6 7 0 1 2 3
	101	5 6 7 0 1 2 3 4	5 4 7 6 1 0 3 2
	110	6 7 0 1 2 3 4 5	6 7 4 5 2 3 0 1
	111	7 0 1 2 3 4 5 6	7 6 5 4 3 2 1 0
Full Page	nnn	Cn, Cn+1, Cn+2	Not supported

Refresh Mode

SDRAM has two refresh modes, Auto Refresh and Self Refresh. Auto Refresh is similar to the $\overline{\text{CAS}}$ -before- $\overline{\text{RAS}}$ refresh of conventional DRAMs. All of banks must be precharged before applying any refresh mode. An on-chip address counter increments the word and the bank addresses and no bank information is required for both refresh modes.

The chip enters the Auto Refresh mode, when $\overline{\text{RAS}}$ and $\overline{\text{CAS}}$ are held low and $\overline{\text{CKE}}$ and $\overline{\text{WE}}$ are held high at a clock timing. The mode restores word line after the refresh and no external precharge command is necessary. A minimum t_{RC} time is required between two automatic refreshes in a burst refresh mode. The same rule applies to any access command after the automatic refresh operation.

The chip has an on-chip timer and the Self Refresh mode is available. It enters the mode when $\overline{\text{RAS}}$, $\overline{\text{CAS}}$, and $\overline{\text{CKE}}$ are low and $\overline{\text{WE}}$ is high at a clock timing. All of external control signals including the clock are disabled. Returning $\overline{\text{CKE}}$ to high enables the clock and initiates the refresh exit operation. After the exit command, at least one t_{RC} delay is required prior to any access command.

DQM Function

DQM has two functions for data I/O read and write operations. During reads, when it turns to "high" at a clock timing, data outputs are disabled and become high impedance after two clock delay (DQM Data Disable Latency t_{DQZ}). It also provides

a data mask function for writes. When DQM is activated, the write operation at the next clock is prohibited (DQM Write Mask Latency t_{DQW} = zero clocks).

Power Down

In order to reduce standby power consumption, a power down mode is available. All banks must be precharged and the necessary Precharge delay (t_{rp}) must occur before the SDRAM can enter the Power Down mode. Once the Power Down mode is initiated by holding $\overline{\text{CKE}}$ low, all of the receiver circuits except CLK and $\overline{\text{CKE}}$ are gated off. The Power Down mode does not perform any refresh operations, therefore the device can't remain in Power Down mode longer than the Refresh period (t_{ref}) of the device. Exit from this mode is performed by taking $\overline{\text{CKE}}$ "high". One clock delay is required for mode entry and exit.

Auto Precharge

Two methods are available to precharge SDRAMs. In an automatic precharge mode, the CAS timing accepts one extra address, CA10, to determine whether the chip restores or not after the operation. If CA10 is high when a Read Command is issued, the **Read with Auto-Precharge** function is initiated. The SDRAM automatically enters the precharge operation one clock before the last data out for CAS latencies 2, two clocks for CAS latencies 3 and three clocks for CAS latencies 4. If CA10 is high when a Write Command is issued, the **Write**

with **Auto-Precharge** function is initiated. The SDRAM automatically enters the precharge operation a time delay equal to t_{WR} (Write recovery time) after the last data in.

Precharge Command

There is also a separate precharge command available. When \overline{RAS} and \overline{WE} are low and \overline{CAS} is high at a clock timing, it triggers the precharge operation. Three address bits, BA0, BA1 and A10 are used to define banks as shown in the following list. The precharge command can be imposed one clock before the last data out for CAS latency = 2, two clocks before the last data out for CAS latency = 3. Writes require a time delay t_{wr} from the last data out to apply the precharge command.

Bank Selection by Address Bits:

A10	BA0	BA1	
0	0	0	Bank 0
0	0	1	Bank 1
0	1	0	Bank 2
0	1	1	Bank 3
1	X	X	all Banks

Burst Termination

Once a burst read or write operation has been initiated, there are several methods in which to terminate the burst operation prematurely. These methods include using another Read or Write Command to interrupt an existing burst operation, use a Precharge Command to interrupt a burst cycle and close the active bank, or using the Burst Stop Command to terminate the existing burst operation but leave the bank open for future Read or Write Commands to the same page of the active bank. When interrupting a burst with another Read or Write Command care must be taken to avoid I/O contention. The Burst Stop Command, however, has the fewest restrictions making it the easiest method to use when terminating a burst operation before it has been completed. If a Burst Stop command is issued during a burst write operation, then any residual data from the burst write cycle will be ignored. Data that is presented on the I/O pins before the Burst Stop Command is registered will be written to the memory.

Deep Power Down Mode

The Deep Power Down mode is an unique function with very low standby currents. All internal voltage generators inside the RAM are stopped and all memory data is lost in this mode. To enter the Deep Power Down mode all banks must be precharged.

Recommended Operation and Characteristics

$T_A = 0$ to 70 °C(Commercial)/ -25 to 85 °C(Extended); $V_{SS} = 0$ V; $V_{CC} = 2.5$ V, $V_{CCQ} = 1.8$ V

Parameter	Symbol	Limit Values		Unit	Notes
		min.	max.		
Supply voltage	V_{CC}	2.3	2.9	V	
I/O Supply Voltage	V_{CCQ}	1.65	2.9	V	1, 2
Input high voltage	V_{IH}	$0.8 \times V_{CCQ}$	$V_{CC} + 0.3$	V	1, 2
Input low voltage	V_{IL}	-0.3	0.3	V	1, 2
Output high voltage ($I_{OUT} = -4.0$ mA)	V_{OH}	$V_{CCQ} - 0.2$	-	V	
Output low voltage ($I_{OUT} = 4.0$ mA)	V_{OL}	-	0.4	V	
Input leakage current, any input (0 V $< V_{IN} < 3.6$ V, all other inputs = 0 V)	$I_{I(L)}$	-5	5	μ A	
Output leakage current (DQ is disabled, 0 V $< V_{OUT} < V_{CC}$)	$I_{O(L)}$	-5	5	μ A	

Note:

1. All voltages are referenced to V_{SS} .
2. V_{IH} may overshoot to $V_{CC} + 0.8$ V for pulse width of < 4 ns with 2.5V. V_{IL} may undershoot to -0.8 V for pulse width < 4.0 ns with 2.5V. Pulse width measured at 50% points with amplitude measured peak to DC reference.

Absolute Maximum Ratings*

Operating temperature range (commercial) 0 to 70 °C
 Operating temperature range (extended) -25 to 85 °C
 Storage temperature range -55 to 150 °C
 Input/output voltage -0.3 to (V_{CC}+0.3) V
 Power supply voltage -0.3 to 3.6 V
 Power dissipation 0.7 W
 Data out current (short circuit) 50 mA

***Note:** Stresses above those listed under “Absolute Maximum Ratings” may cause permanent damage of the device. Exposure to absolute maximum rating conditions for extended periods may affect device reliability.

Operating Currents T_A = 0 to 70 °C(Commercial)/-25 to 85 °C(Extended);

V_{SS} = 0 V; V_{CC} = 2.5 V, V_{CCQ} = 1.8V(Recommended Operating Conditions unless otherwise noted)

Symbol	Parameter & Test Condition		Max.				Unit	Note
			-6	-7 / -7PC	-8PC	10		
ICC1	Operating Current t _{RC} = t _{RCMIN.} , t _{RC} = t _{CKMIN.} Active-precharge command cycling, without Burst Operation	1 bank operation	190	170	150	130	mA	7
ICC2P	Precharge Standby Current in Power Down Mode	t _{CK} = min.	1.5	1.5	1.5	1.5	mA	7
ICC2PS	$\overline{CS} = V_{IH}$, $CKE \leq V_{IL(max)}$	t _{CK} = Infinity	1	1	1	1	mA	7
ICC2N	Precharge Standby Current in Non-Power Down Mode	t _{CK} = min.	55	45	35	25	mA	
ICC2NS	$\overline{CS} = V_{IH}$, $CKE \geq V_{IL(max)}$	t _{CK} = Infinity	5	5	5	5	mA	
ICC3N	No Operating Current t _{CK} = min, $\overline{CS} = V_{IH(min)}$	CKE ≥ V _{IH(MIN.)}	65	55	45	35	mA	
ICC3P	bank ; active state (4 banks)	CKE ≤ V _{IL(MAX.)} (Power down mode)	10	10	10	10	mA	
ICC4	Burst Operating Current t _{CK} = min Read/Write command cycling		130	110	90	70	mA	7,8
ICC5	Auto Refresh Current t _{CK} = min Auto Refresh command cycling		270	250	210	190	mA	7
ICC7	Deep Power down Current		10	10	10	10	uA	

Notes:

- These parameters depend on the cycle rate and these values are measured by the cycle rate under the minimum value of t_{CK} and t_{RC}. Input signals are changed one time during t_{CK}.
- These parameter depend on output loading. Specified values are obtained with output open.

Temperature Compensated/Partial Array Self-Refresh Currents

Parameter & Test Condition	Extended Mode Register M[4:3] Tcase[°C]	Symb.	Max.	Unit
Self Refresh Current Self refresh Mode CKE=0.2V, tck=infinity, full array activations, all banks	85°C max	ICC6	520	uA
	70°C max		350	uA
	45°C max		250	uA
	15°C max		210	uA
Self Refresh Current Self refresh Mode CKE=0.2V, tck=infinity, 1/2 array activations, Bank 0+1	85°C max	ICC6	380	uA
	70°Cmax		250	uA
	45°C max		180	uA
	15°Cmax		160	uA
Self Refresh Current Self refresh Mode CKE=0.2V, tck=infinity, 1/4 array activations, Bank 0	85°C max	ICC6	270	uA
	70°C max		180	uA
	45°C max		130	uA
	15°C max		120	uA
Self Refresh Current Self refresh Mode CKE=0.2V, tck=infinity, 1/8 array activations, Bank 0	85°C max	ICC6	190	uA
	70°C max		140	uA
	45°C max		100	uA
	15°C max		90	uA
Self Refresh Current Self refresh Mode CKE=0.2V, tck=infinity, 1/16 array activations, Bank 0	85°C max	ICC6	130	uA
	70°C max		110	uA
	45°C max		90	uA
	15°C max		80	uA

AC Characteristics ^{1,2,3}

T_A = 0 to 70 °C(Commercial)/-25 to 85 °C(Extended); V_{SS} = 0 V; V_{CC} = 2.5 V, V_{CCQ} = 1.8V, t_T = 1 ns

#	Symbol	Parameter	Limit Values										Unit	Note
			-6		-7PC		-7		-8PC		-10			
			Min.	Max.	Min.	Max.	Min.	Max.	Min.	Max.	Min.	Max.		
Clock and Clock Enable														
1	t _{CK}	Clock Cycle Time	6	-	7	-	7	-	8	-	10	-	ns	
		$\overline{\text{CAS}}$ Latency = 3	7.5	-	7.5	-	10	-	10	-	12	-	ns	
		$\overline{\text{CAS}}$ Latency = 2	20	-	20	-	20	-	20	-	25	-	ns	
2	t _{CK}	Clock Frequency	-	166	-	143	-	143	-	125	-	100	MHz	
		$\overline{\text{CAS}}$ Latency = 3	-	133	-	133	-	100	-	100	-	83	MHz	
		$\overline{\text{CAS}}$ Latency = 1	-	50	-	50	-	50	-	50	-	40	MHz	
3	t _{AC}	Access Time from Clock	-	5.4	-	5.4	-	5.4	-	6	-	7	ns	2, 4
		$\overline{\text{CAS}}$ Latency = 3	-	5.4	-	5.4	-	6	-	6	-	8	ns	
		$\overline{\text{CAS}}$ Latency = 1	-	19	-	19	-	19	-	19	-	22	ns	
4	t _{CH}	Clock High Pulse Width	2.5	-	2.5	-	2.5	-	3	-	3	-	ns	
5	t _{CL}	Clock Low Pulse Width	2.5	-	2.5	-	2.5	-	3	-	3	-	ns	
6	t _T	Transition Tim	0.3	1.2	0.3	1.2	0.3	1.2	0.5	10	0.5	10	ns	
Setup and Hold Times														
7	t _{IS}	Input Setup Time	1.5	-	1.5	-	1.5	-	2	-	2.5	-	ns	5
8	t _{IH}	Input Hold Time	0.8	-	0.8	-	0.8	-	1	-	1	-	ns	5
9	t _{CKS}	Input Setup Time	1.5	-	1.5	-	1.5	-	2	-	2.5	-	ns	5
10	t _{CKH}	CKE Hold Time	0.8	-	0.8	-	0.8	-	1	-	1	-	ns	5
11	t _{RSC}	Mode Register Set-up Time	12	-	14	-	14	-	16	-	20	-	ns	
12	t _{SB}	Power Down Mode Entry Time	0	6	0	7	0	7	0	8	0	8	ns	
Common Parameters														
13	t _{RCD}	Row to Column Delay Time	12	-	15	-	15	-	20	-	20	-	ns	6
14	t _{RP}	Row Precharge Time	15	-	15	-	15	-	20	-	20	-	ns	6
15	t _{RAS}	Row Active Time	40	100K	42	100K	42	100K	45	100k	50	100k	ns	6
16	t _{RC}	Row Cycle Time	60	-	60	-	60	-	60	-	70	-	ns	6
17	t _{RRD}	Activate(a) to Activate(b) Command Period	12	-	14	-	14	-	16	-	20	-	ns	6
18	t _{CCD}	$\overline{\text{CAS}}$ (a) to $\overline{\text{CAS}}$ (b) Command Period	1	-	1	-	1	-	1	-	1	-	CLK	
Refresh Cycle														

AC Characteristics (Cont'd)

#	Symbol	Parameter	Limit Values										Unit	Note
			-6		-7PC		-7		-8PC		-10			
			Min.	Max.	Min.	Max.	Min.	Max.	Min.	Max.	Min.	Max.		
19	t _{REF}	Refresh Period (4096 cycles)	—	64	—	64	—	64	—	64	—	64	ms	
20	t _{SREX}	Self Refresh Exit Time	1	—	1	—	1	—	1	—	1	—	CLK	
Read Cycle														
21	t _{OH}	Data Out Hold Time	3	—	3	—	3	—	3	—	3	—	ns	2
22	t _{LZ}	Data Out to Low Impedance Time	1	—	1	—	1	—	1	—	1	—	ns	
23	t _{HZ}	Data Out to High Impedance Time	3	6	3	7	3	7	3	7	3	7	ns	7
24	t _{DQZ}	DQM Data Out Disable Latency	—	2	—	2	—	2	—	2	—	2	CLK	
Write Cycle														
25	t _{WR}	Write Recovery Time	1	—	1	—	1	—	1	—	1	—	CLK	
26	t _{DQW}	DQM Write Mask Latency	0	—	0	—	0	—	0	—	0	—	CLK	

Notes for AC Parameters:

- For proper power-up see the operation section of this data sheet.
- AC timing tests are referenced to the 0.9V crossover point for VCCQ=1.8V components. The transition time is measured between V_{IH} and V_{IL}. All AC measurements assume t_T = 1ns with the AC output load circuit shown in

Figure 1.

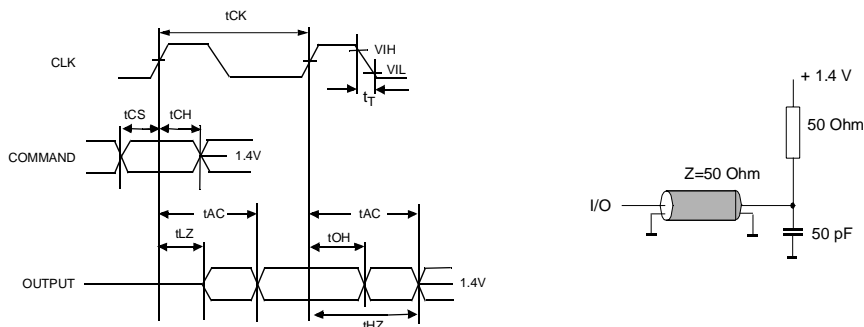

Figure 1.

- If clock rising time is longer than 1 ns, a time (t_T/2 – 0.5) ns has to be added to this parameter.
- If t_T is longer than 1 ns, a time (t_T – 1) ns has to be added to this parameter.
- These parameter account for the number of clock cycle and depend on the operating frequency of the clock, as follows:

the number of clock cycle = specified value of timing period (counted in fractions as a whole number)

Self Refresh Exit is a synchronous operation and begins on the 2nd positive clock edge after CKE returns high. Self Refresh Exit is not complete until a time period equal to t_{RC} is satisfied once the Self Refresh Exit command is registered.

- Referenced to the time which the output achieves the open circuit condition, not to output voltage levels

Timing Diagrams

1. Bank Activate Command Cycle
2. Burst Read Operation
3. Read Interrupted by a Read
4. Read to Write Interval
 - 4.1 Read to Write Interval
 - 4.2 Minimum Read to Write Interval
 - 4.3 Non-Minimum Read to Write Interval
5. Burst Write Operation
6. Write and Read Interrupt
 - 6.1 Write Interrupted by a Write
 - 6.2 Write Interrupted by Read
7. Burst Write & Read with Auto-Precharge
 - 7.1 Burst Write with Auto-Precharge
 - 7.2 Burst Read with Auto-Precharge
8. Burst Termination
 - 8.1 Termination of a Burst Write Operation
 - 8.2 Termination of a Burst Write Operation
9. AC- Parameters
 - 9.1 AC Parameters for a Write Timing
 - 9.2 AC Parameters for a Read Timing
10. Mode Register Set
11. Power on Sequence and Auto Refresh (CBR)
12. Power Down Mode
13. Self Refresh (Entry and Exit)
14. Auto Refresh (CBR)

Timing Diagrams (Cont'd)

15. Random Column Read (Page within same Bank)

15.1 $\overline{\text{CAS}}$ Latency = 215.2 $\overline{\text{CAS}}$ Latency = 3

16. Random Column Write (Page within same Bank)

16.1 $\overline{\text{CAS}}$ Latency = 216.2 $\overline{\text{CAS}}$ Latency = 3

17. Random Row Read (Interleaving Banks) with Precharge

17.1 $\overline{\text{CAS}}$ Latency = 217.2 $\overline{\text{CAS}}$ Latency = 3

18. Random Row Write (Interleaving Banks) with Precharge

18.1 $\overline{\text{CAS}}$ Latency = 218.2 $\overline{\text{CAS}}$ Latency = 3

19. Precharge Termination of a Burst

19.1 $\overline{\text{CAS}}$ Latency = 219.2 $\overline{\text{CAS}}$ Latency = 3

1. Bank Activate Command Cycle

(CAS latency = 3)

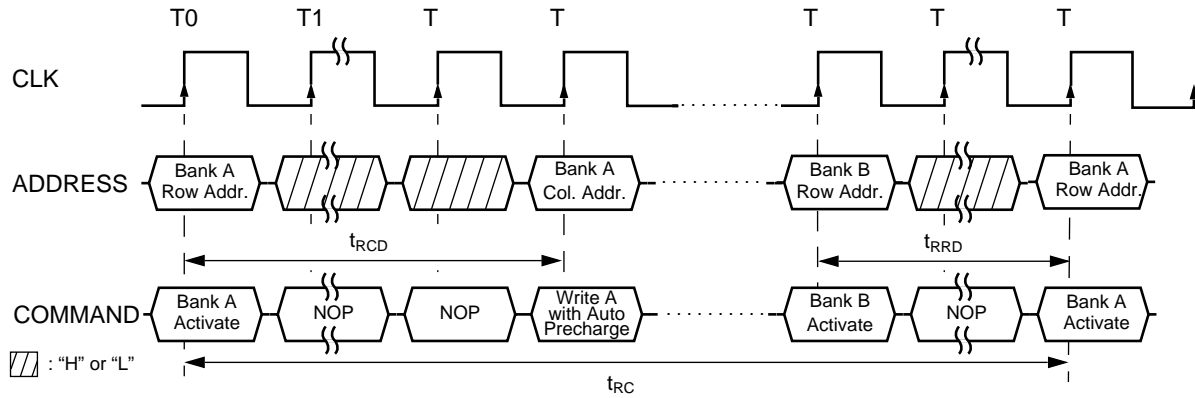

2. Burst Read Operation

(Burst Length = 4, CAS latency = 2, 3)

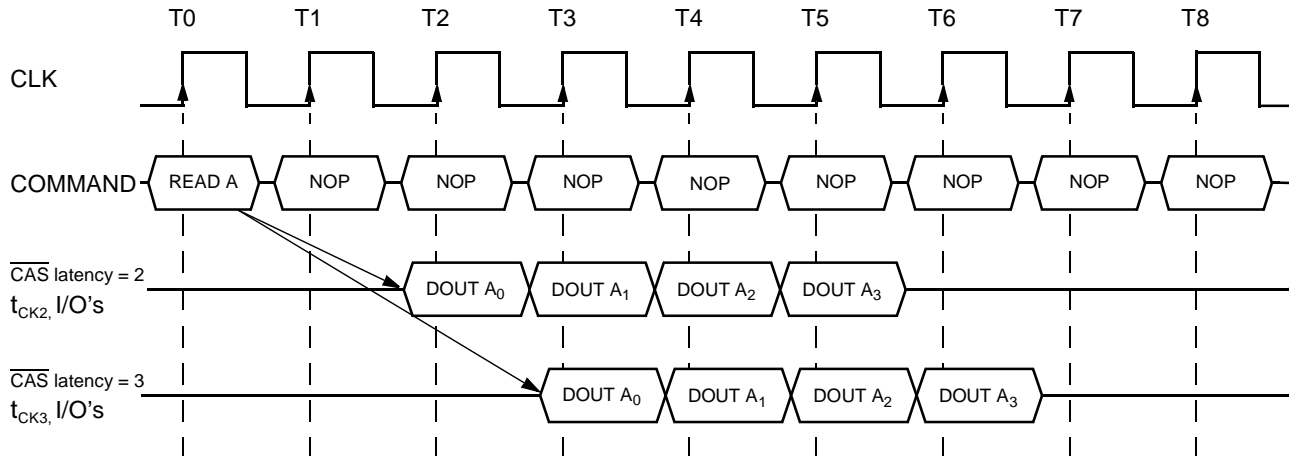

3. Read Interrupted by a Read

(Burst Length = 4, CAS latency = 2, 3)

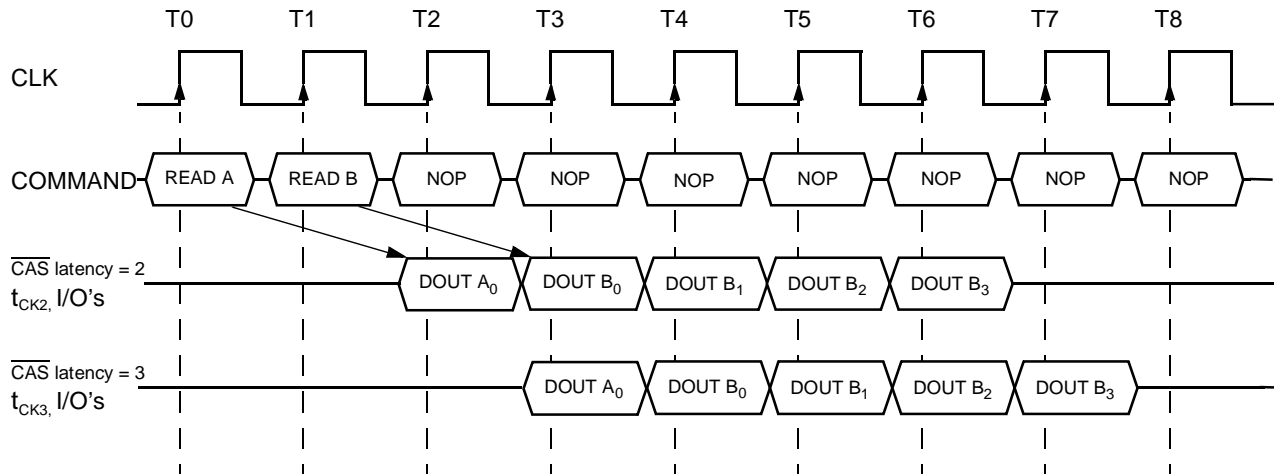

4.1 Read to Write Interval

(Burst Length = 4, CAS latency = 3)

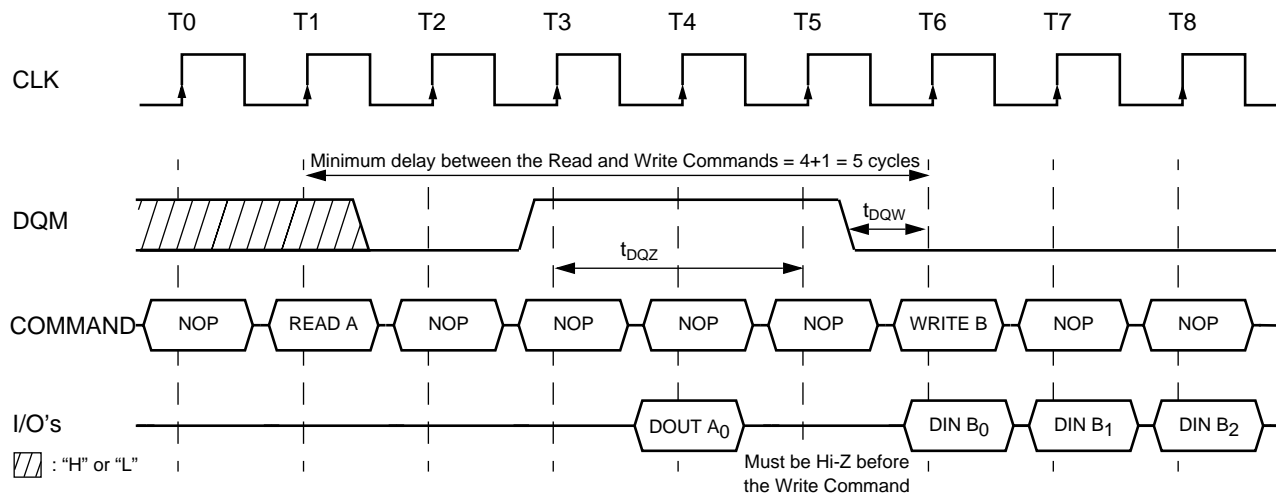

4.2 Minimum Read to Write Interval

(Burst Length = 4, CAS latency = 2)

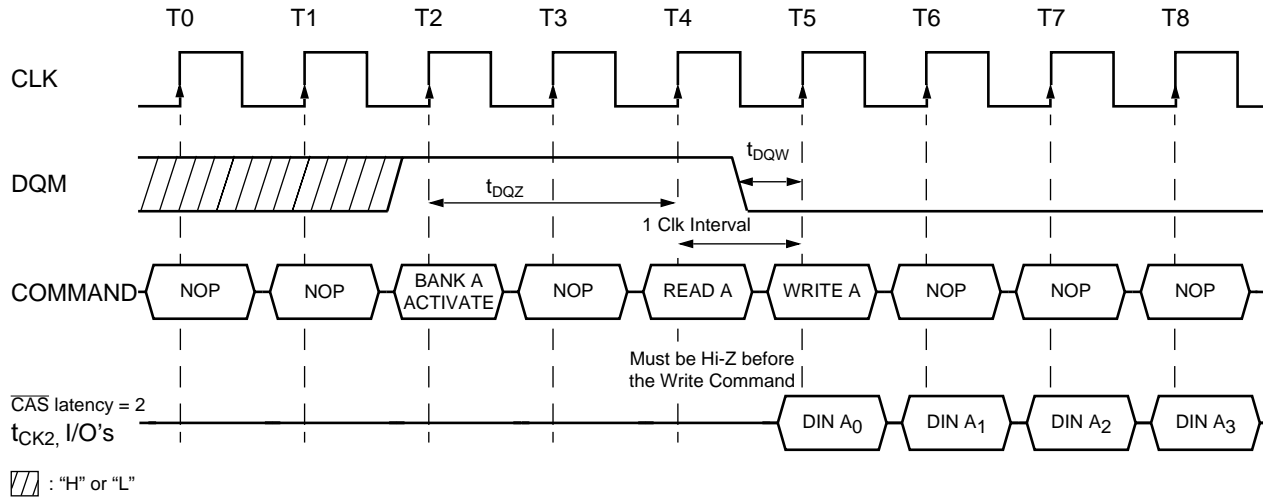

4.3 Non-Minimum Read to Write Interval

(Burst Length = 4, CAS latency = 2, 3)

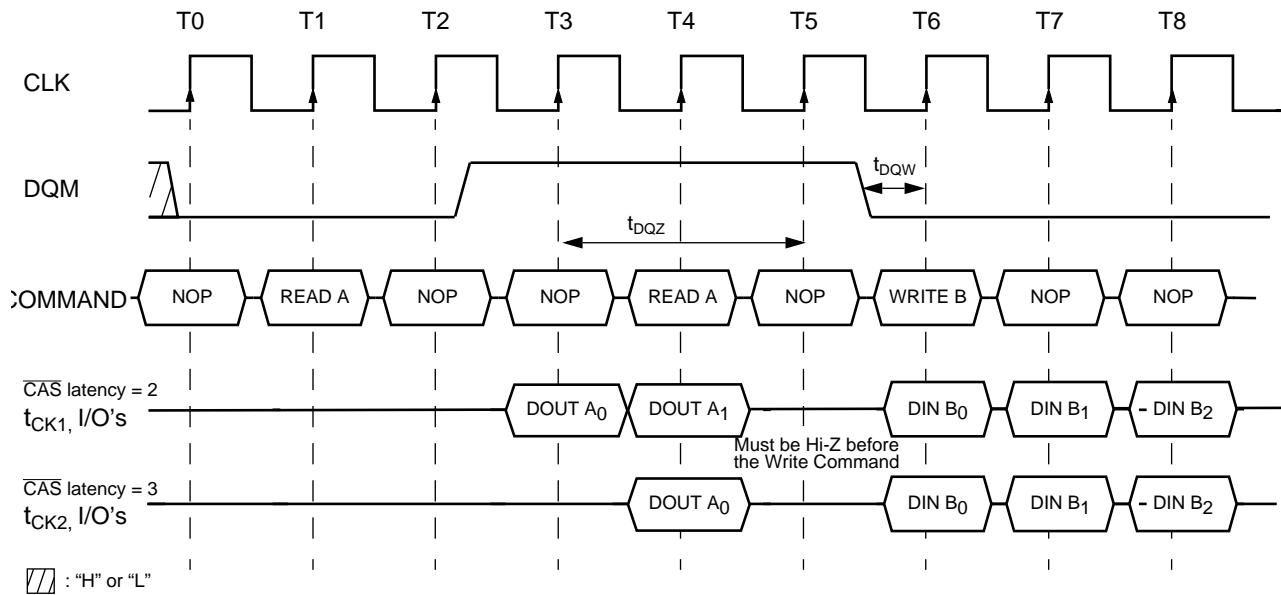

5. Burst Write Operation

(Burst Length = 4, $\overline{\text{CAS}}$ latency = 2, 3)

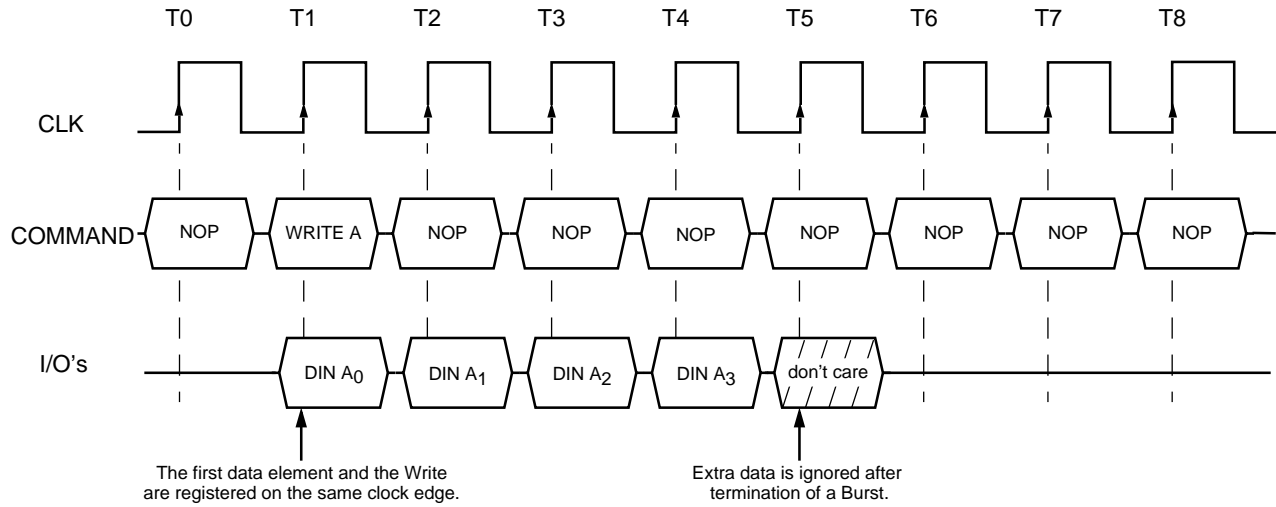

6.1 Write Interrupted by a Write

(Burst Length = 4, $\overline{\text{CAS}}$ latency = 2, 3)

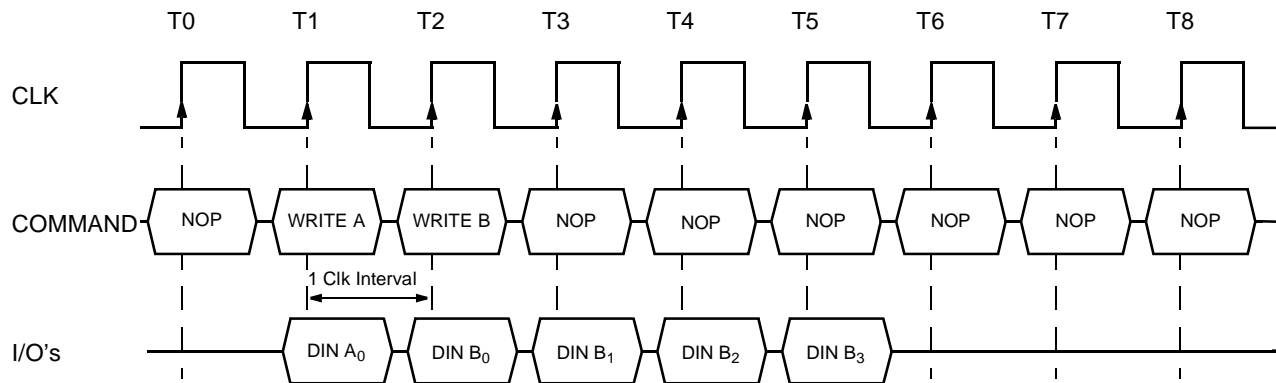

6.2 Write Interrupted by a Read

(Burst Length = 4, $\overline{\text{CAS}}$ latency = 2, 3)

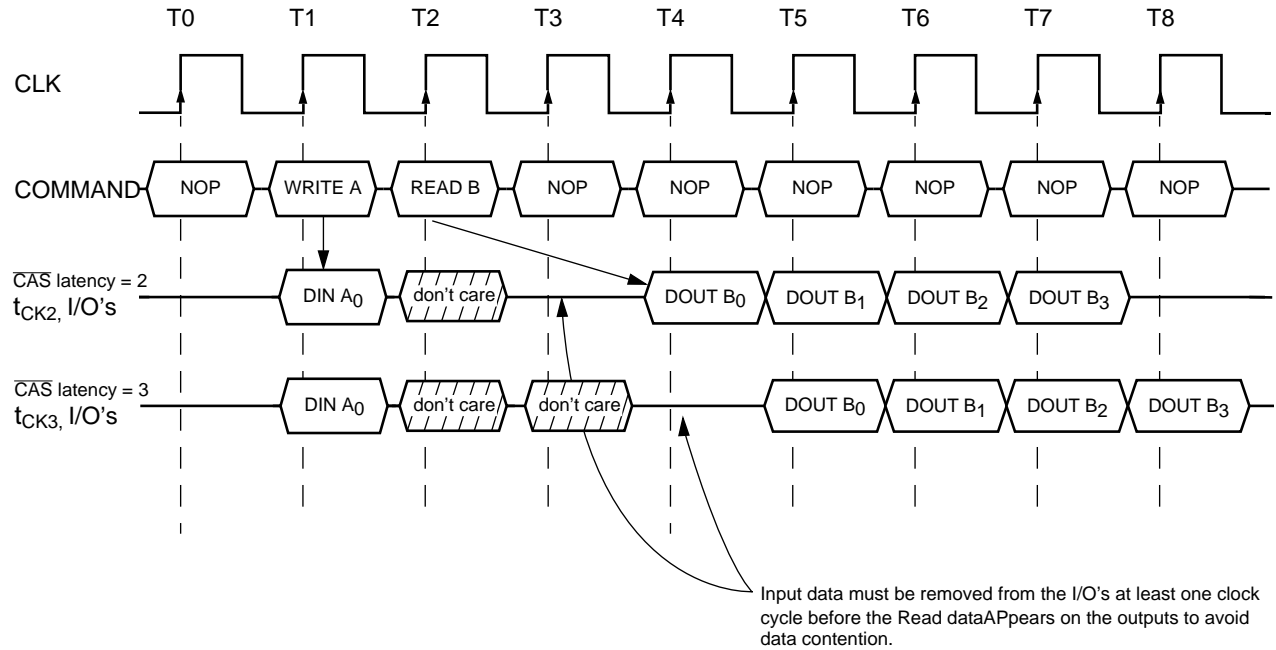

7. Burst Write with Auto-Precharge

(Burst Length = 2, $\overline{\text{CAS}}$ latency = 2, 3)

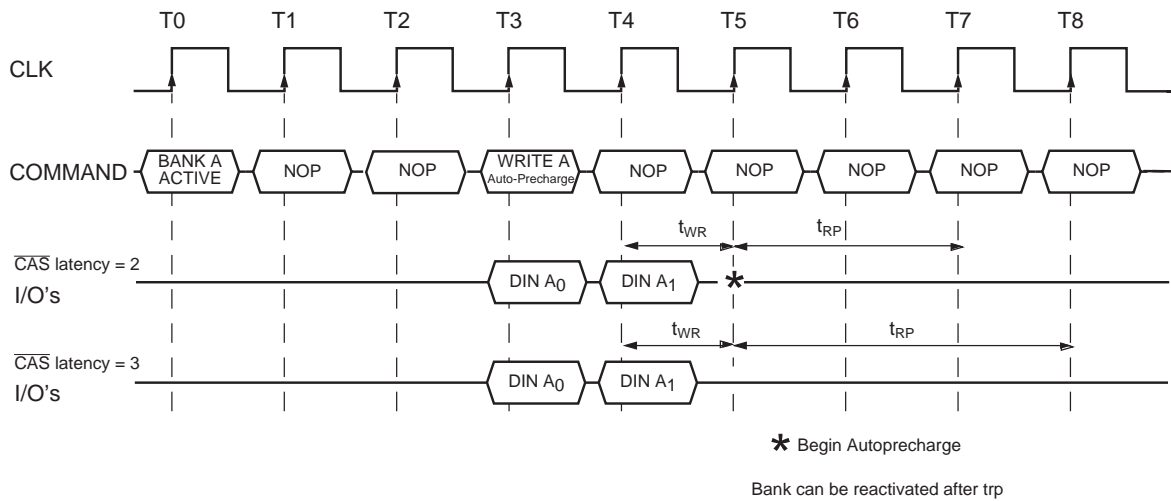

7.2 Burst Read with Auto-Precharge

Burst Length = 4, CAS latency = 2, 3)

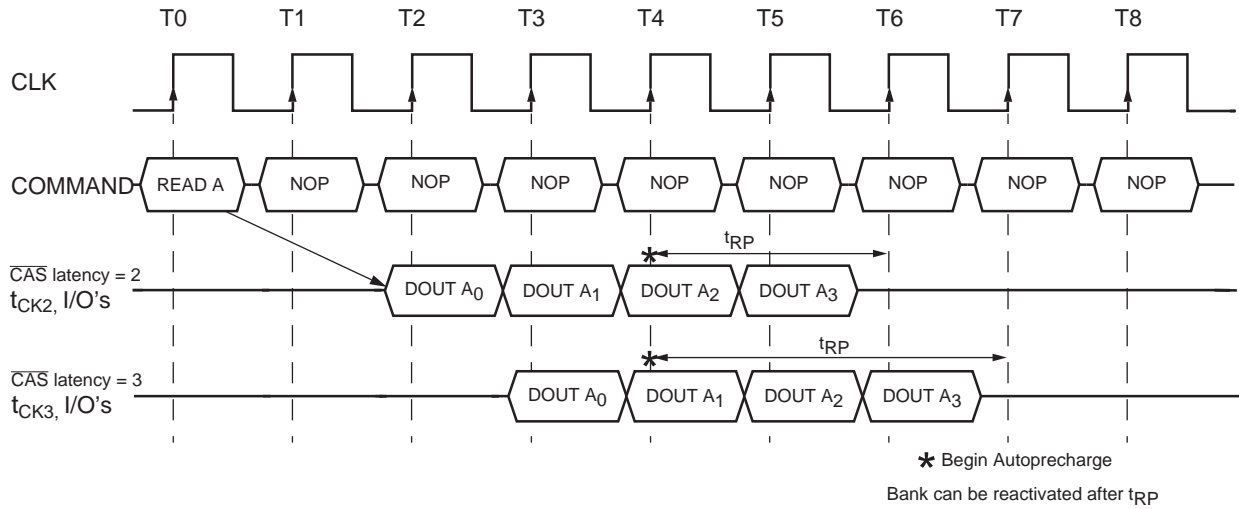

8.1 Termination of a Burst Read Operation

(CAS latency = 2, 3)

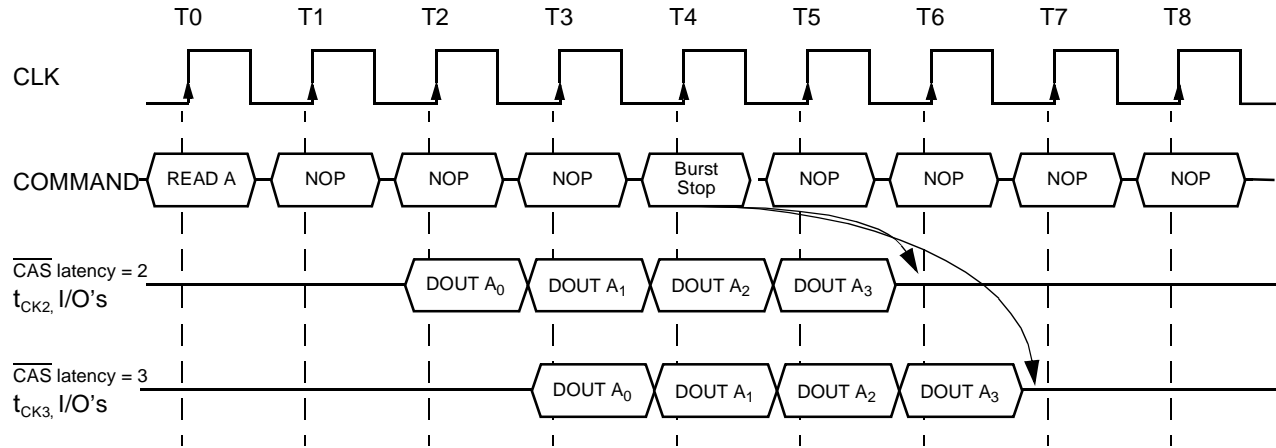

8.2 Termination of a Burst Write Operation

(CAS latency = 2, 3)

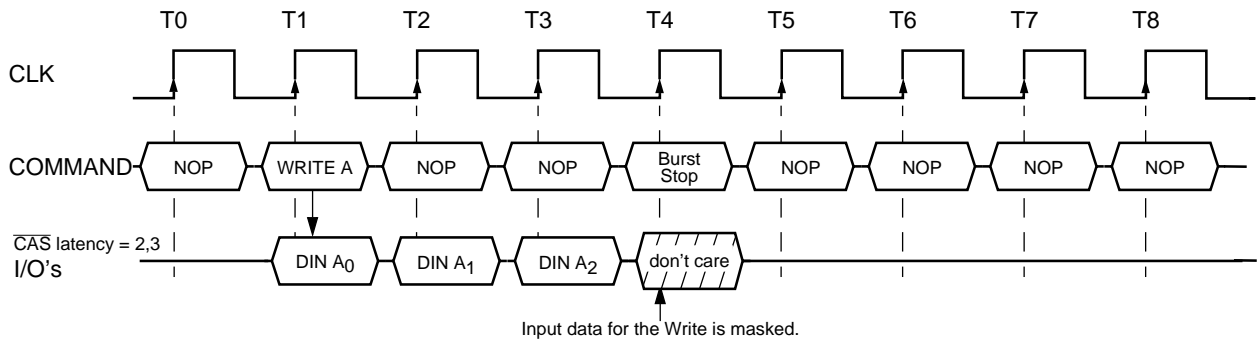

Burst Length = 4, CAS Latency = 2

9.1 AC Parameters for Write Timing

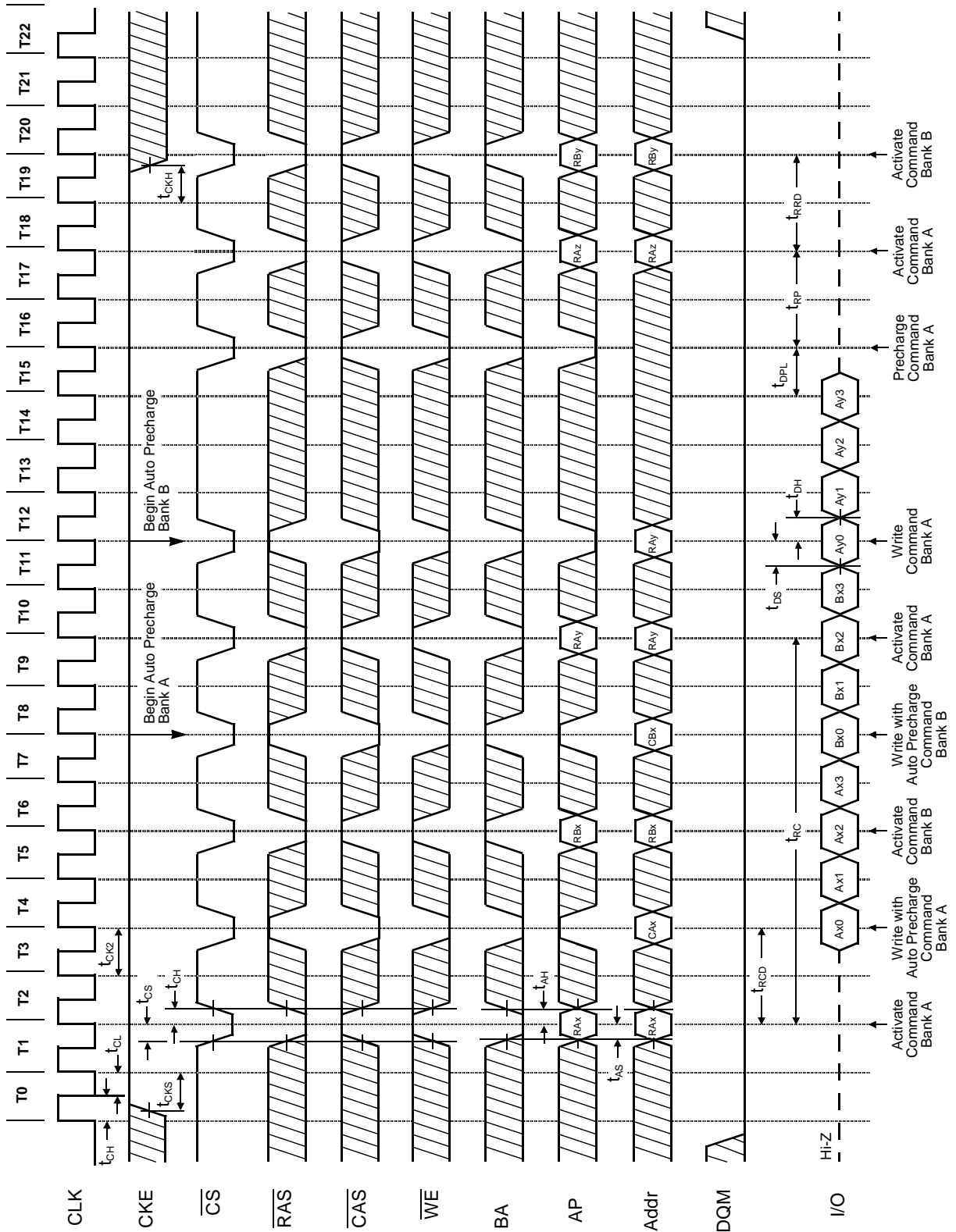

Burst Length = 2, CAS Latency = 2

9.2 AC Parameters for Read Timing

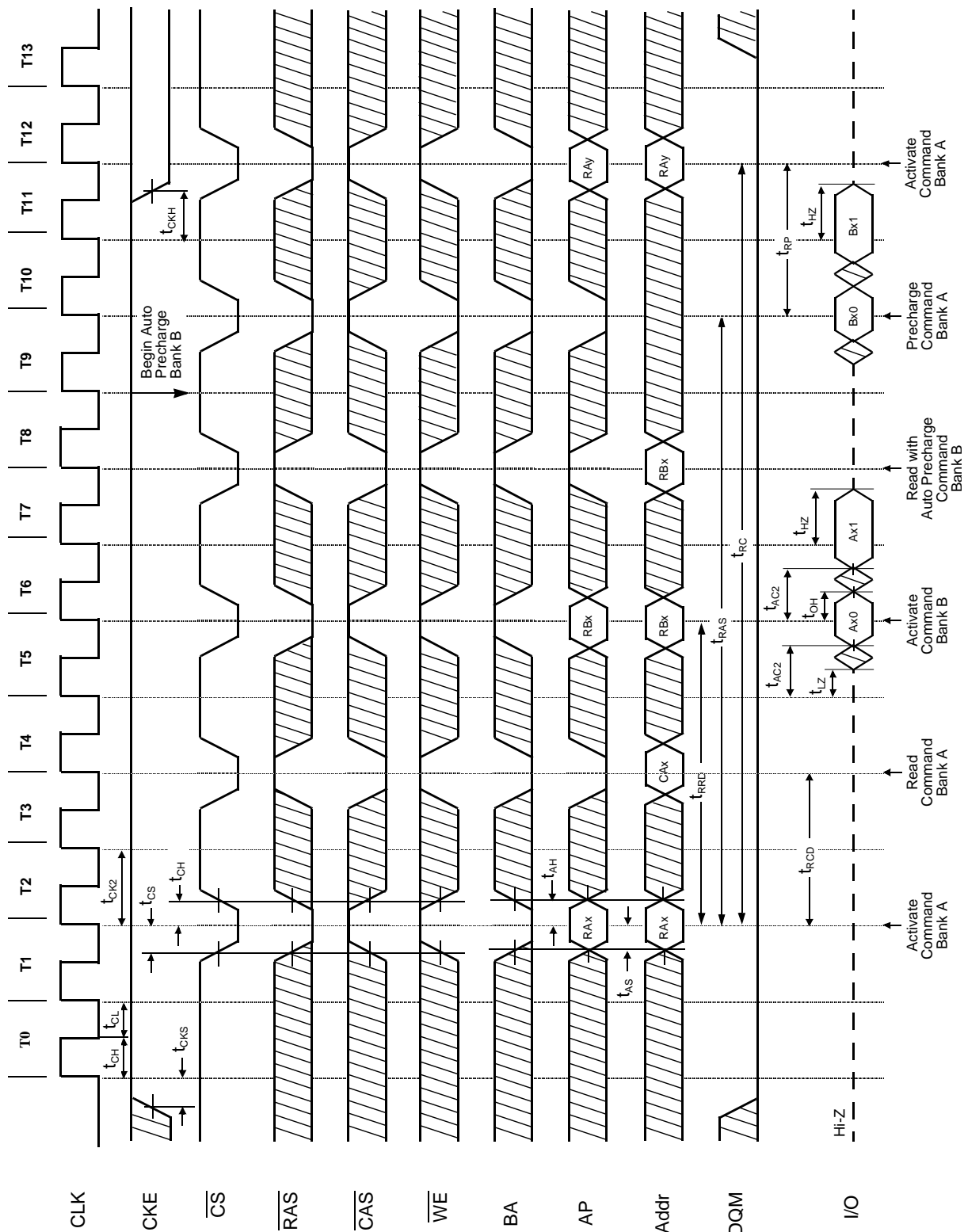

10. Mode Register Set

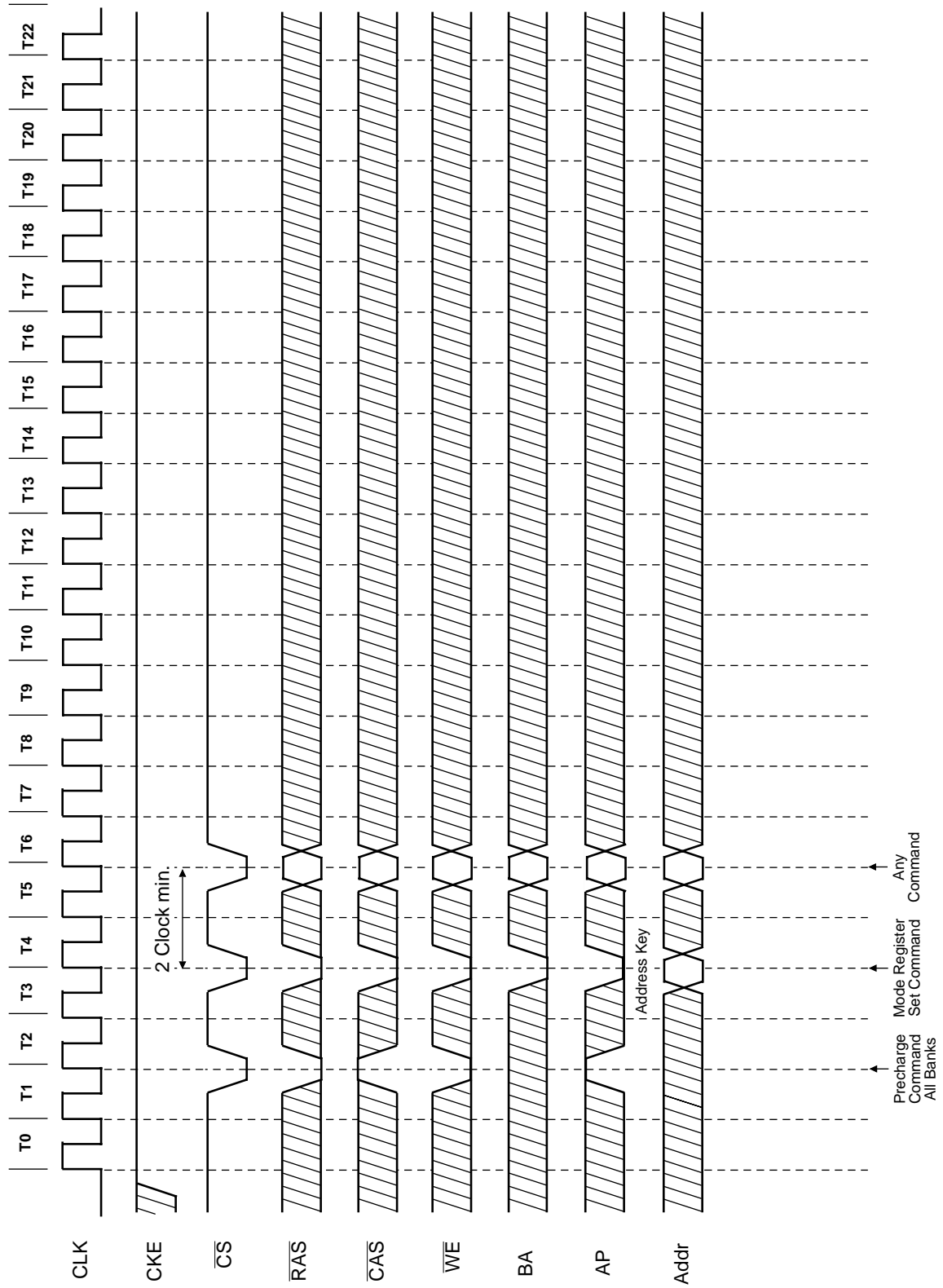

11. Power on Sequence and Auto Refresh (CBR)

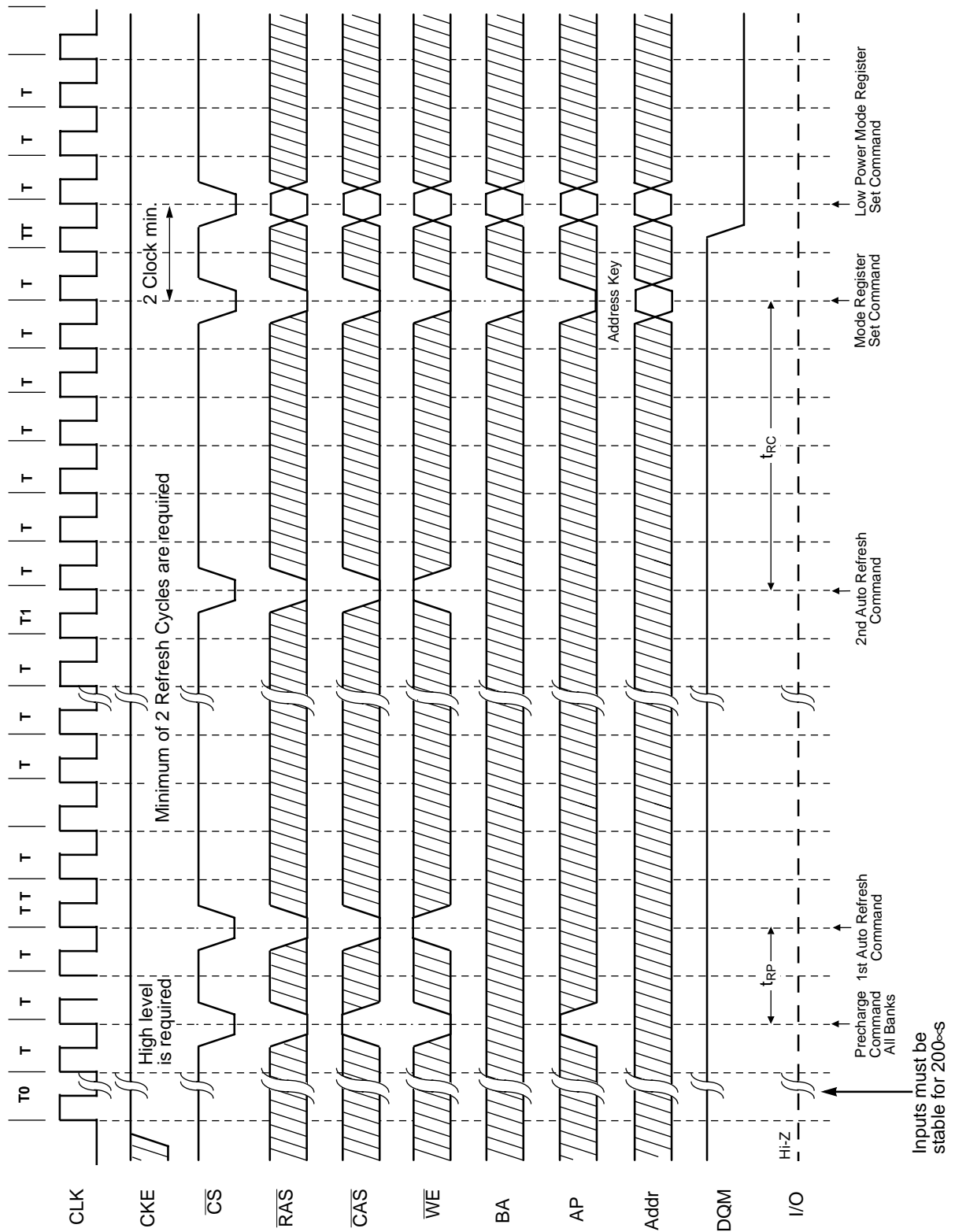

Burst Length = 4, CAS Latency = 2

12. Power Down Mode

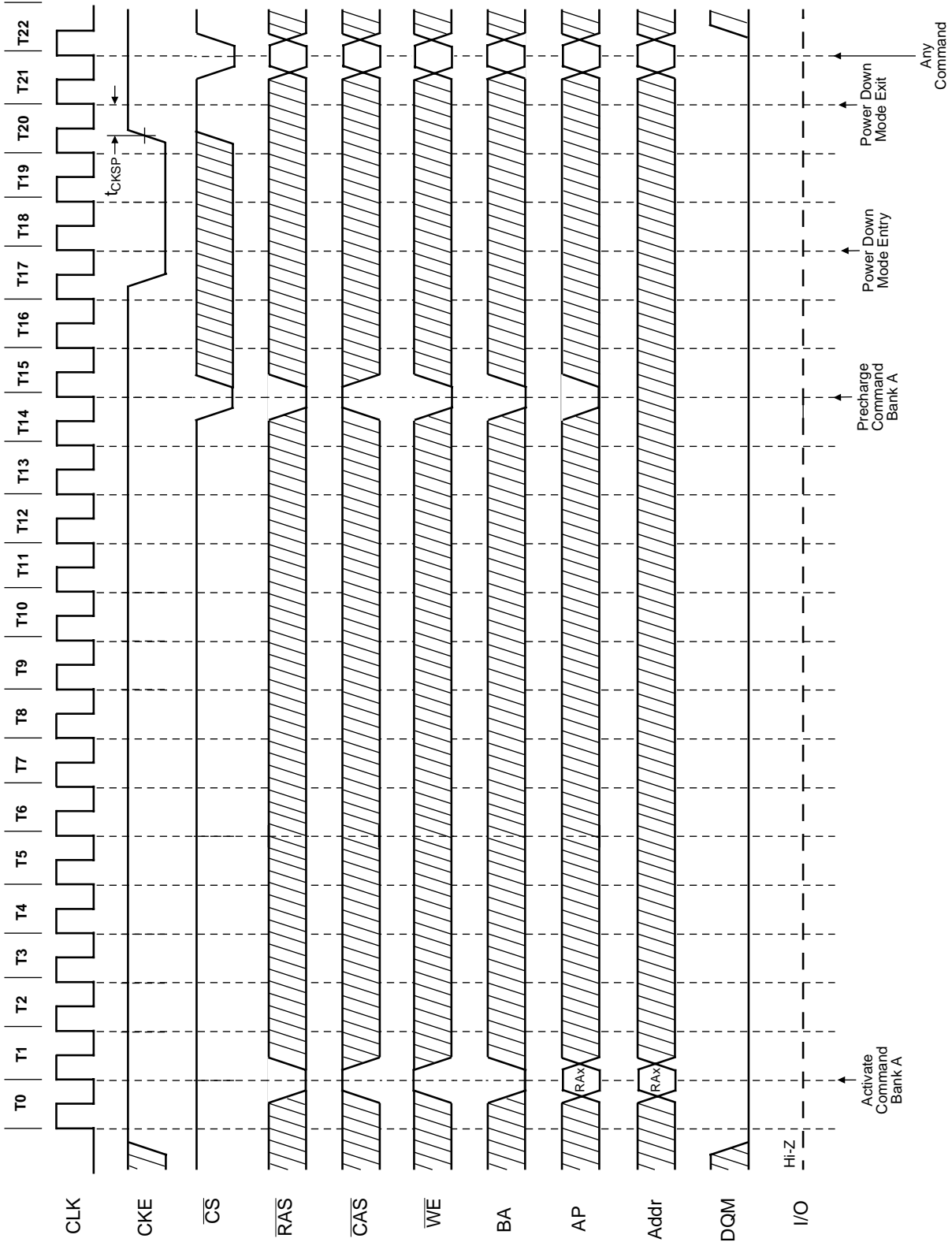

13. Self Refresh (Entry and Exit)

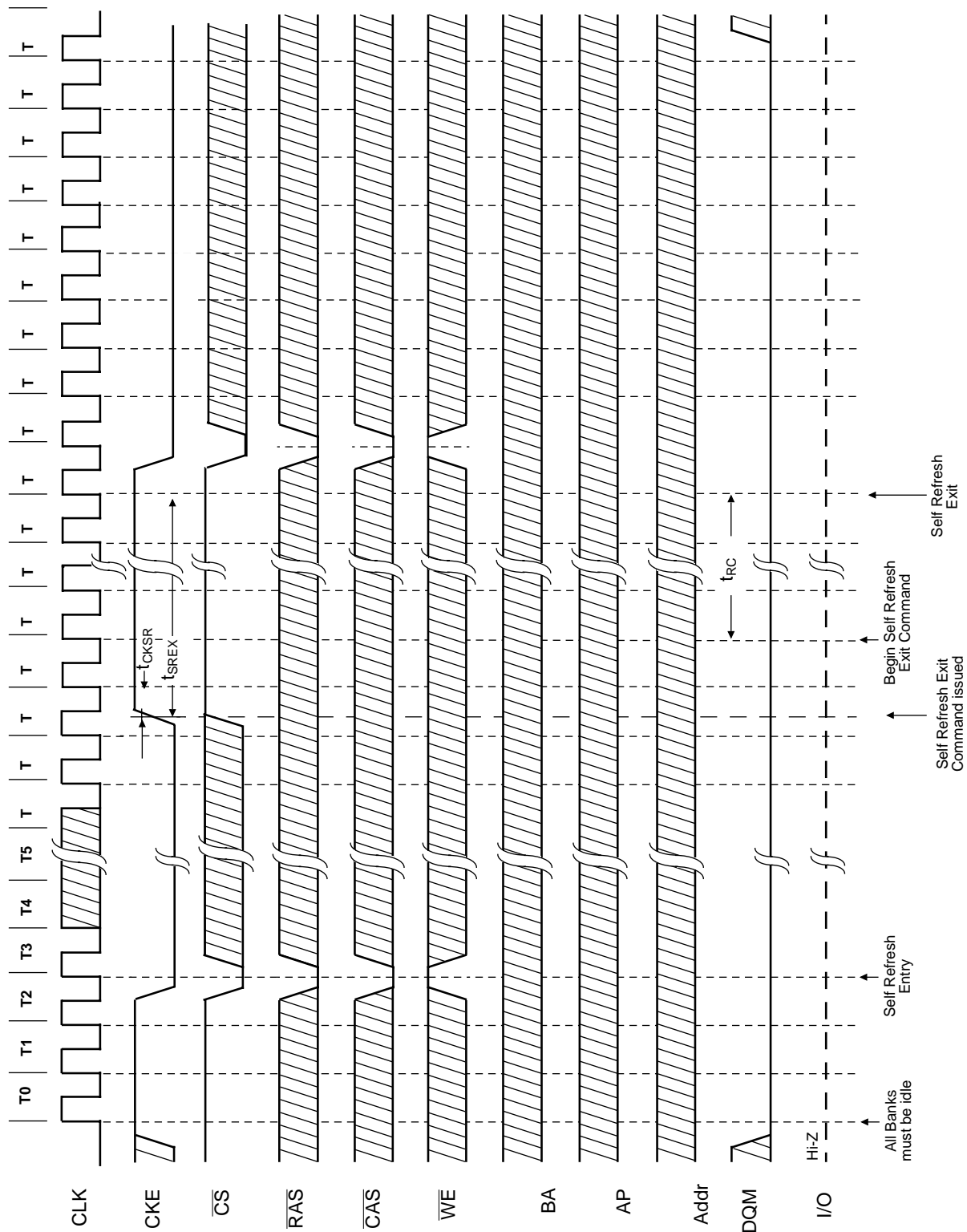

14. Auto Refresh (CBR)

Burst Length = 4, CAS Latency = 2

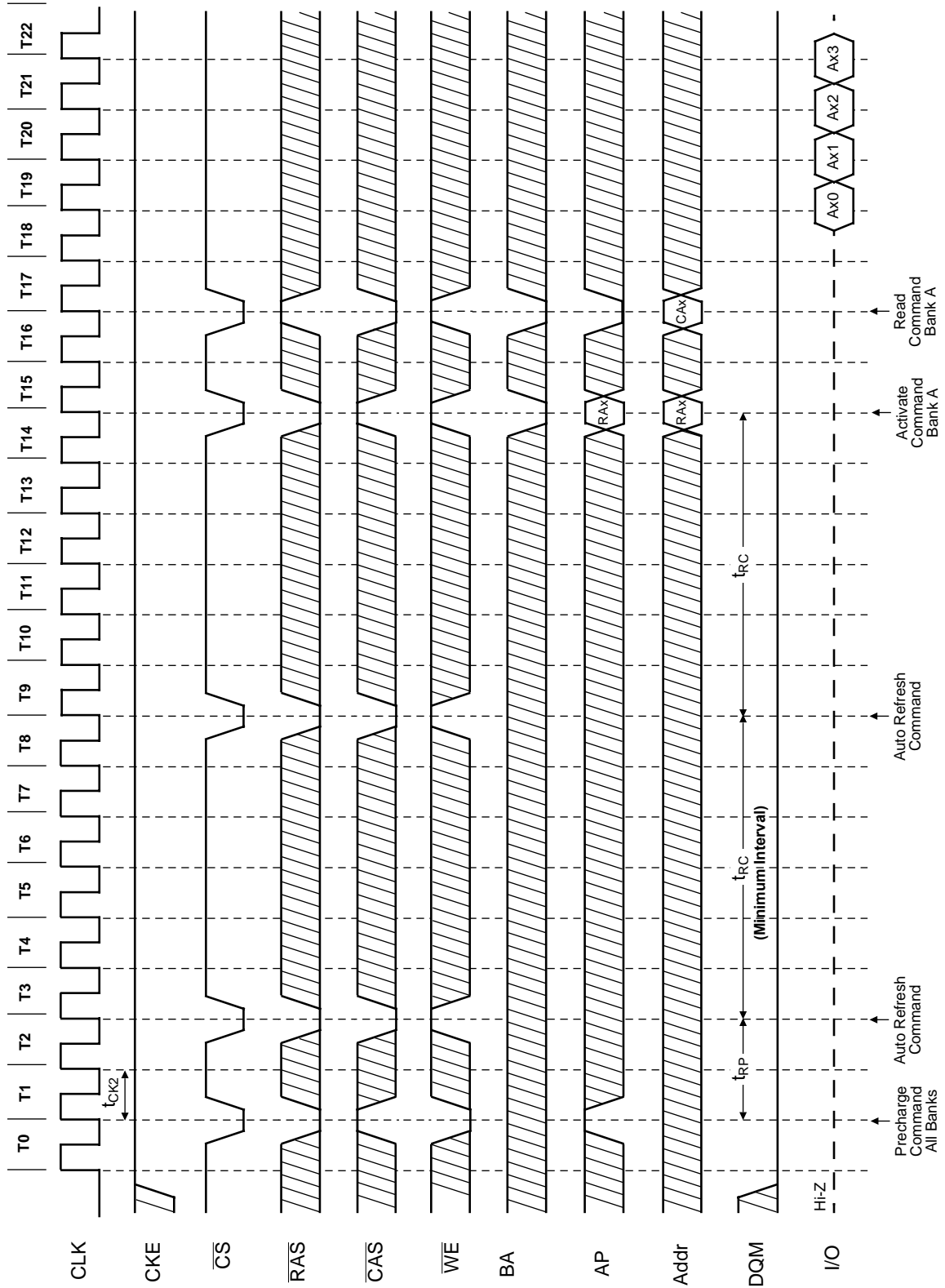

15.1 Random Column Read (Page within same Bank) (1 of 2)

Burst Length = 4, CAS Latency = 2

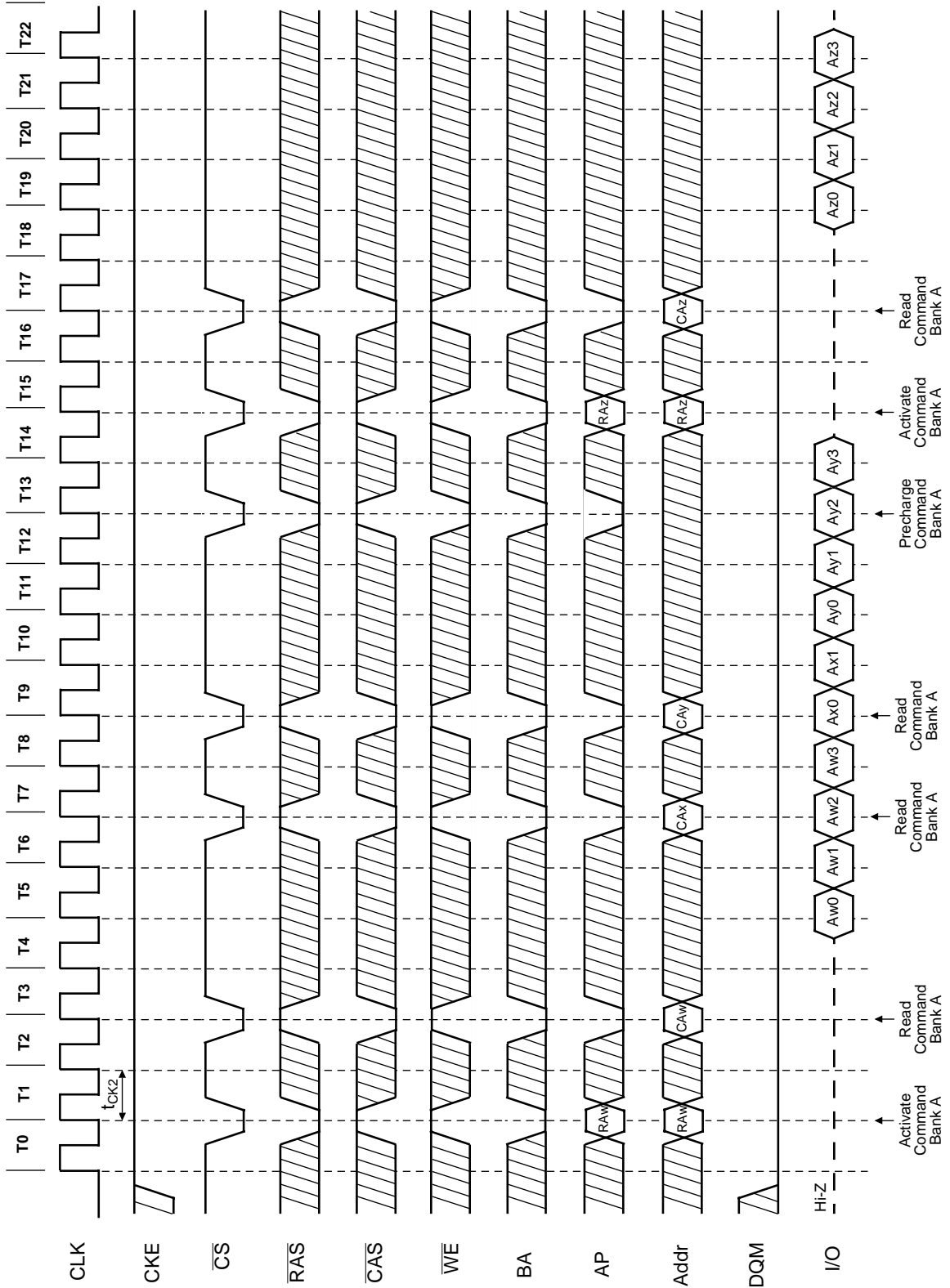

15.2 Random Column Read (Page within same Bank) (2 of 2)

Burst Length = 4, CAS Latency = 3

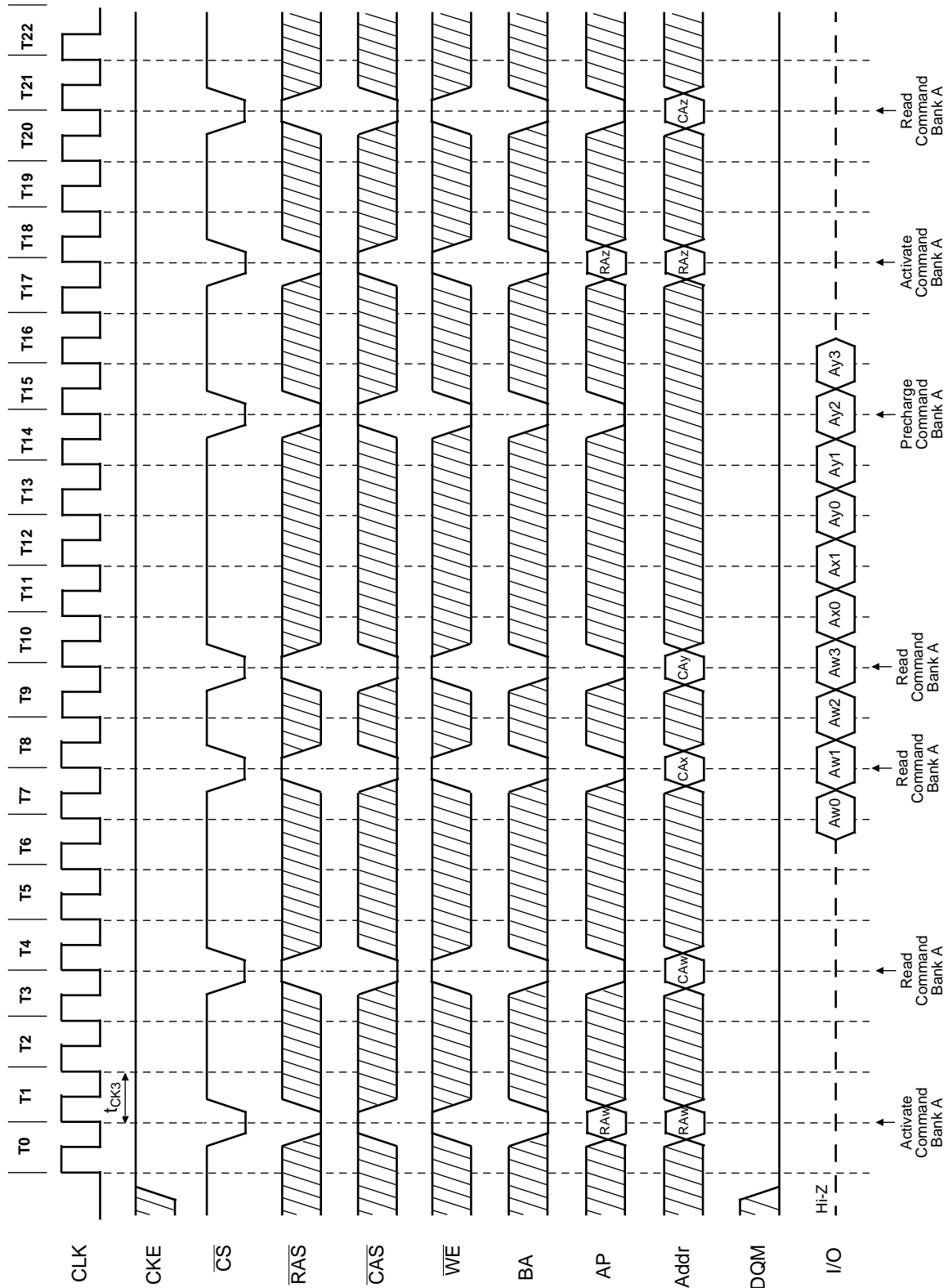

16.1 Random Column Write (Page within same Bank) (1 of 2)

Burst Length = 4, CAS Latency = 2

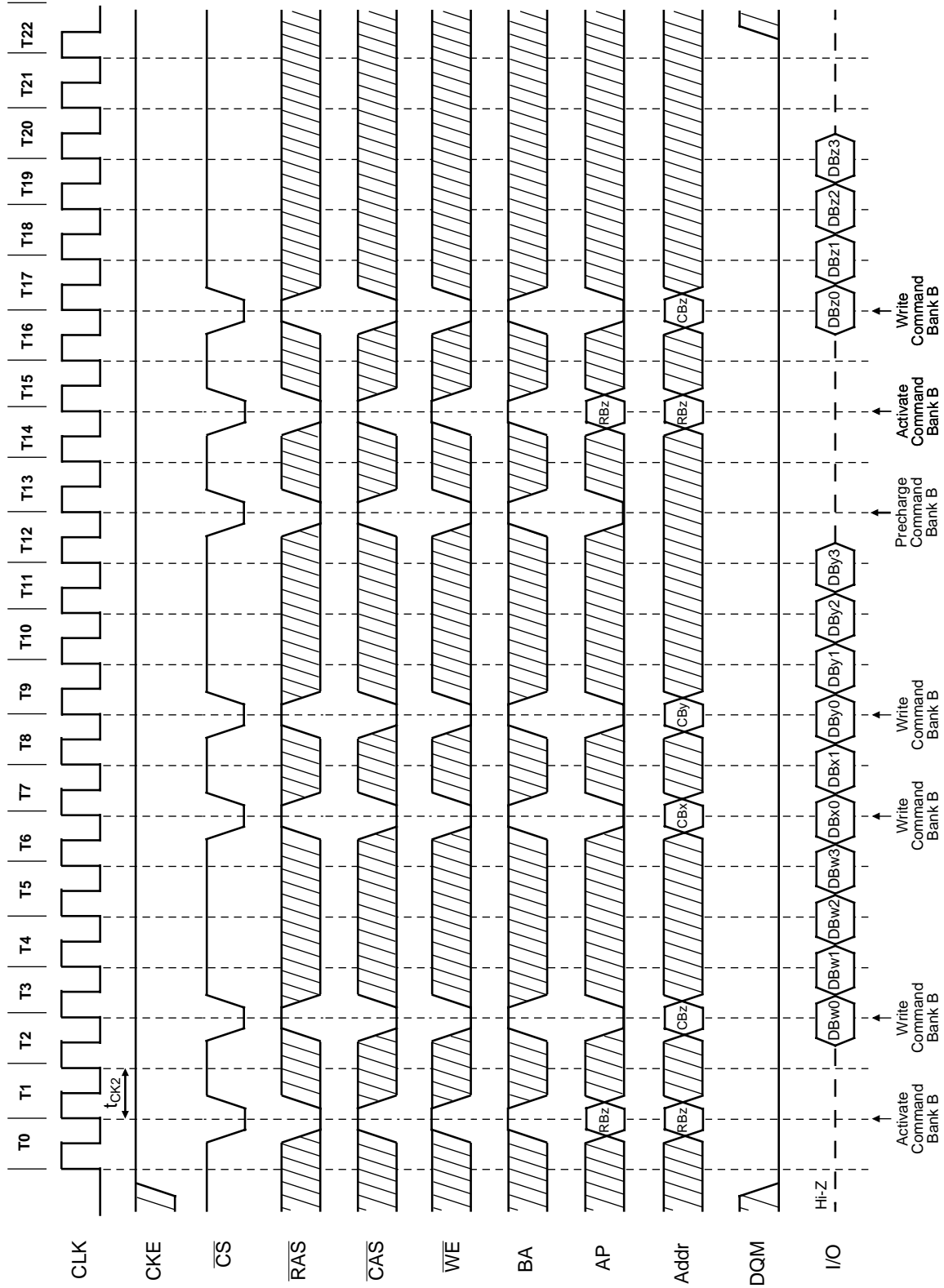

16.2 Random Column Write (Page within same Bank) (2 of 2)

Burst Length = 4, CAS Latency = 3

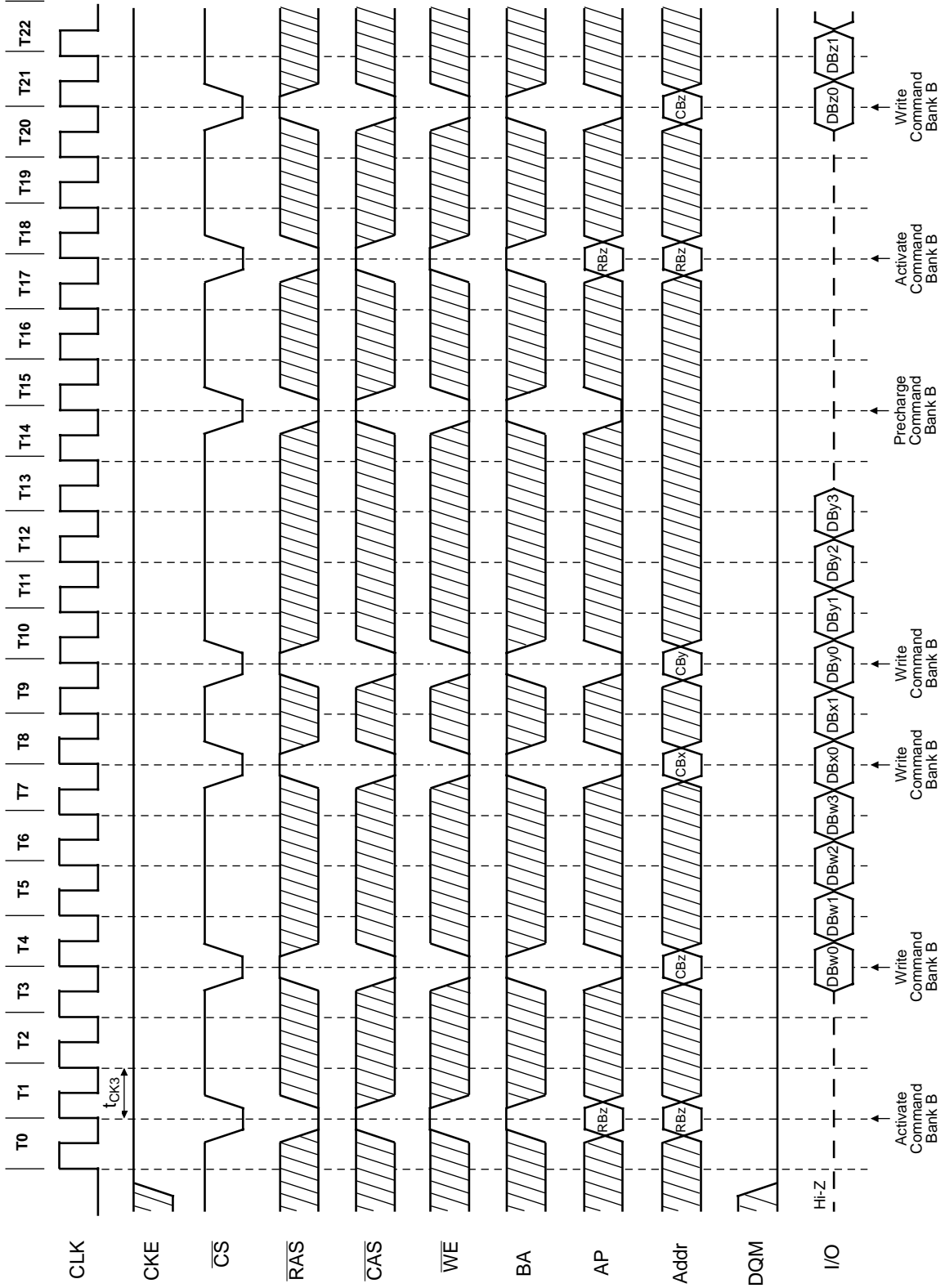

Burst Length = 8, CAS Latency = 2

17.1 Random Row Read (Interleaving Banks) (1 of 2)

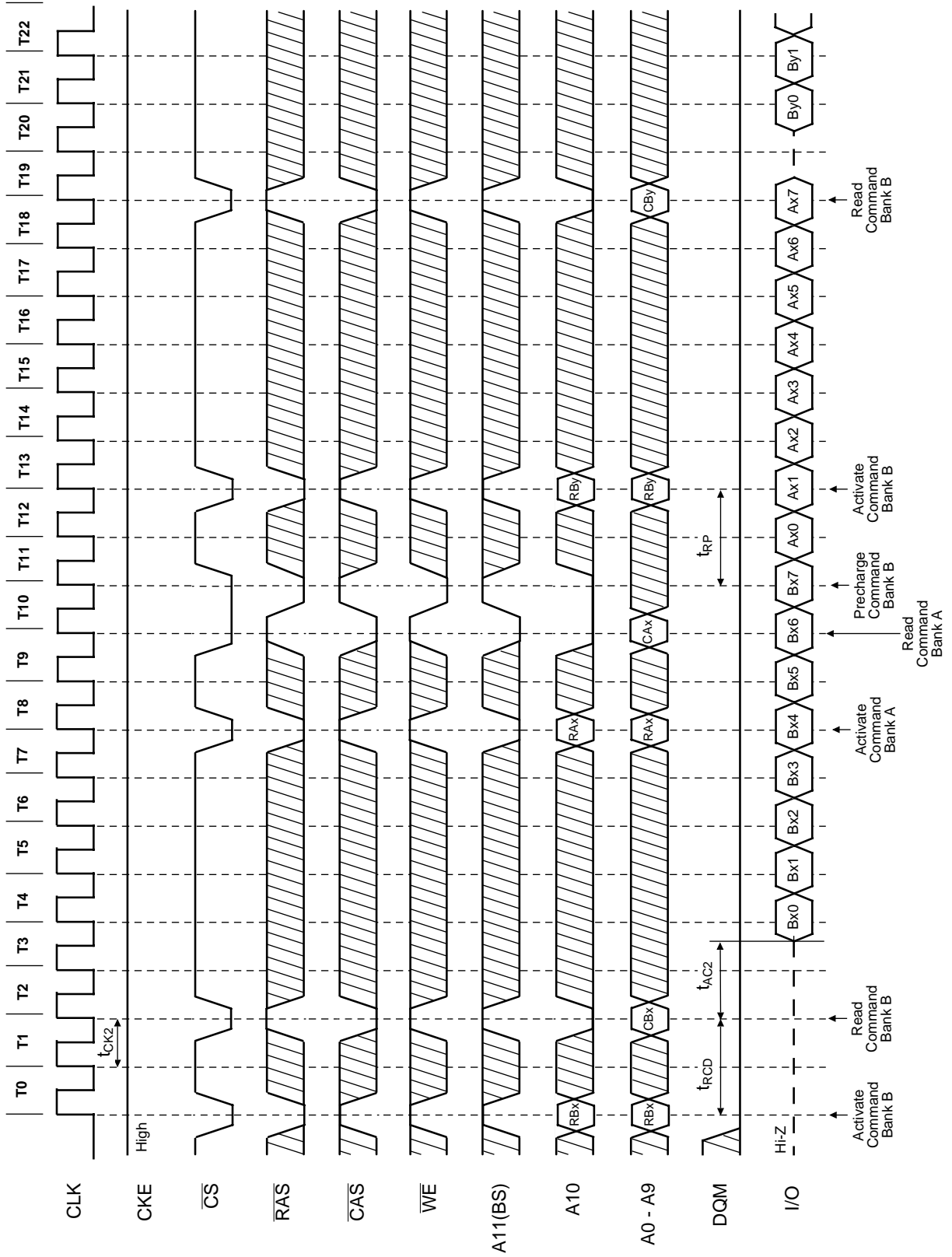

Burst Length = 8, CAS Latency = 3

17.2 Random Row Read (Interleaving Banks) (2 of 2)

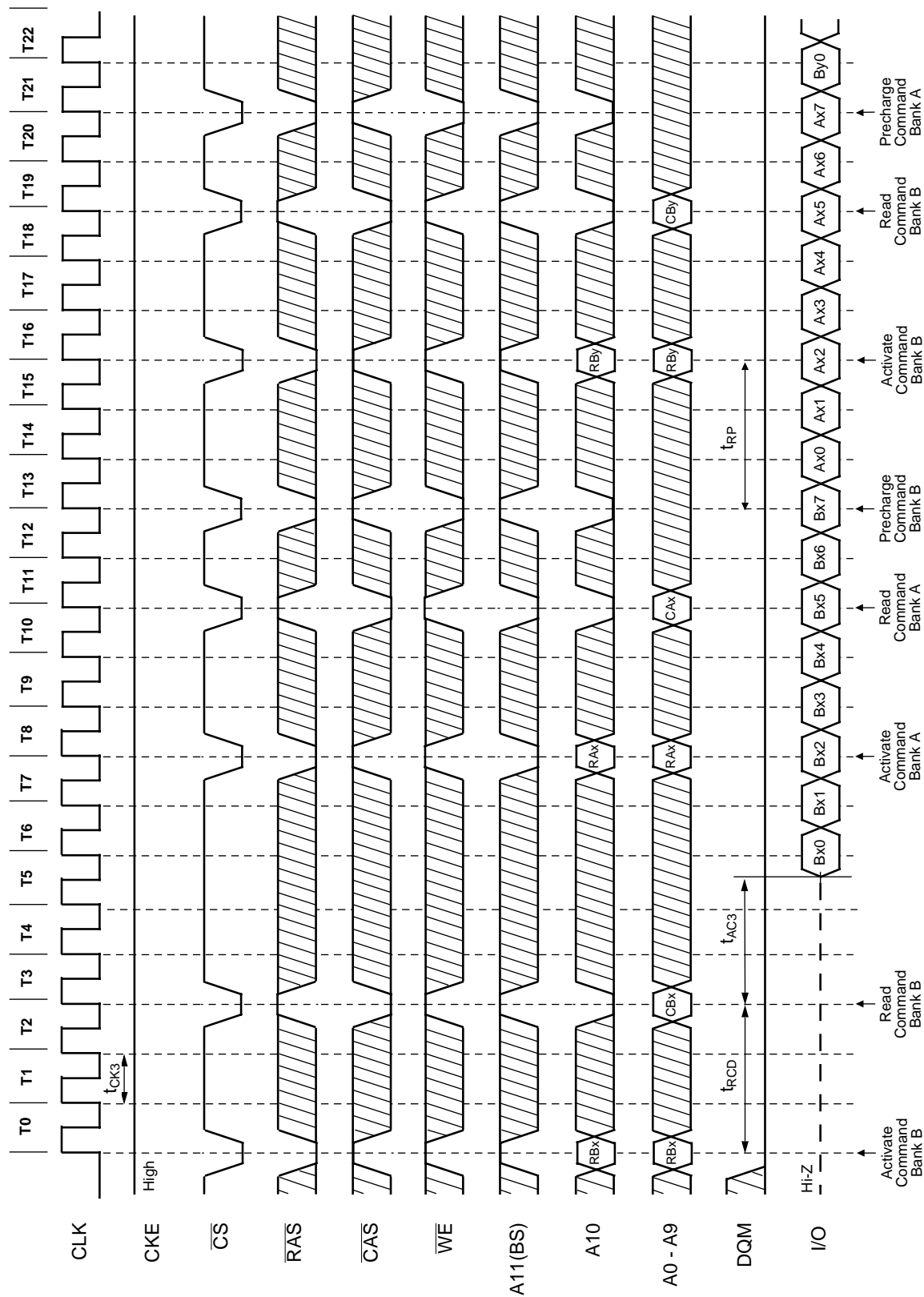

Burst Length = 8, CAS Latency = 2

18.1 Random Row Write (Interleaving Banks) (1 of 2)

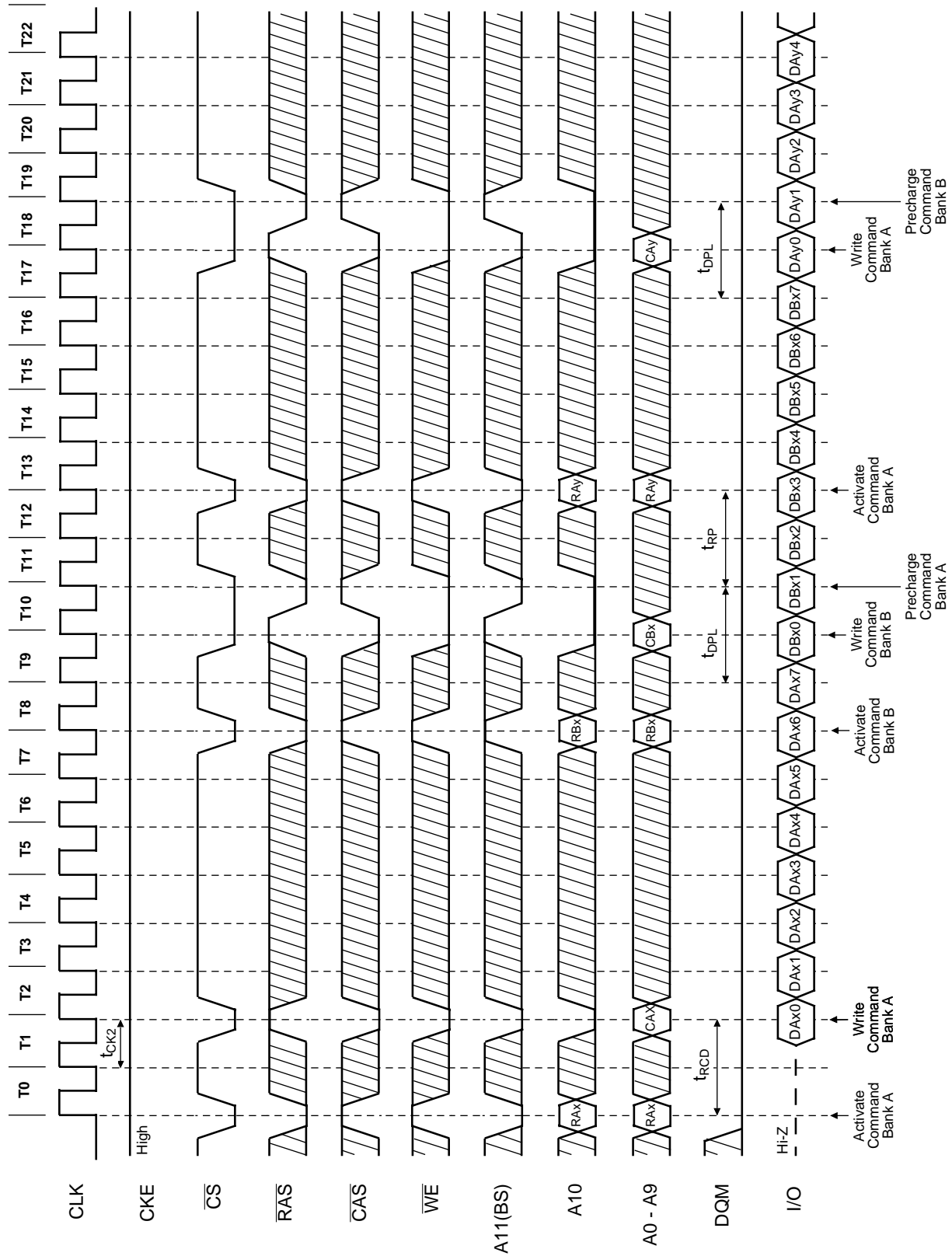

Burst Length = 8, CAS Latency = 3

18.2 Random Row Write (Interleaving Banks) (2 of 2)

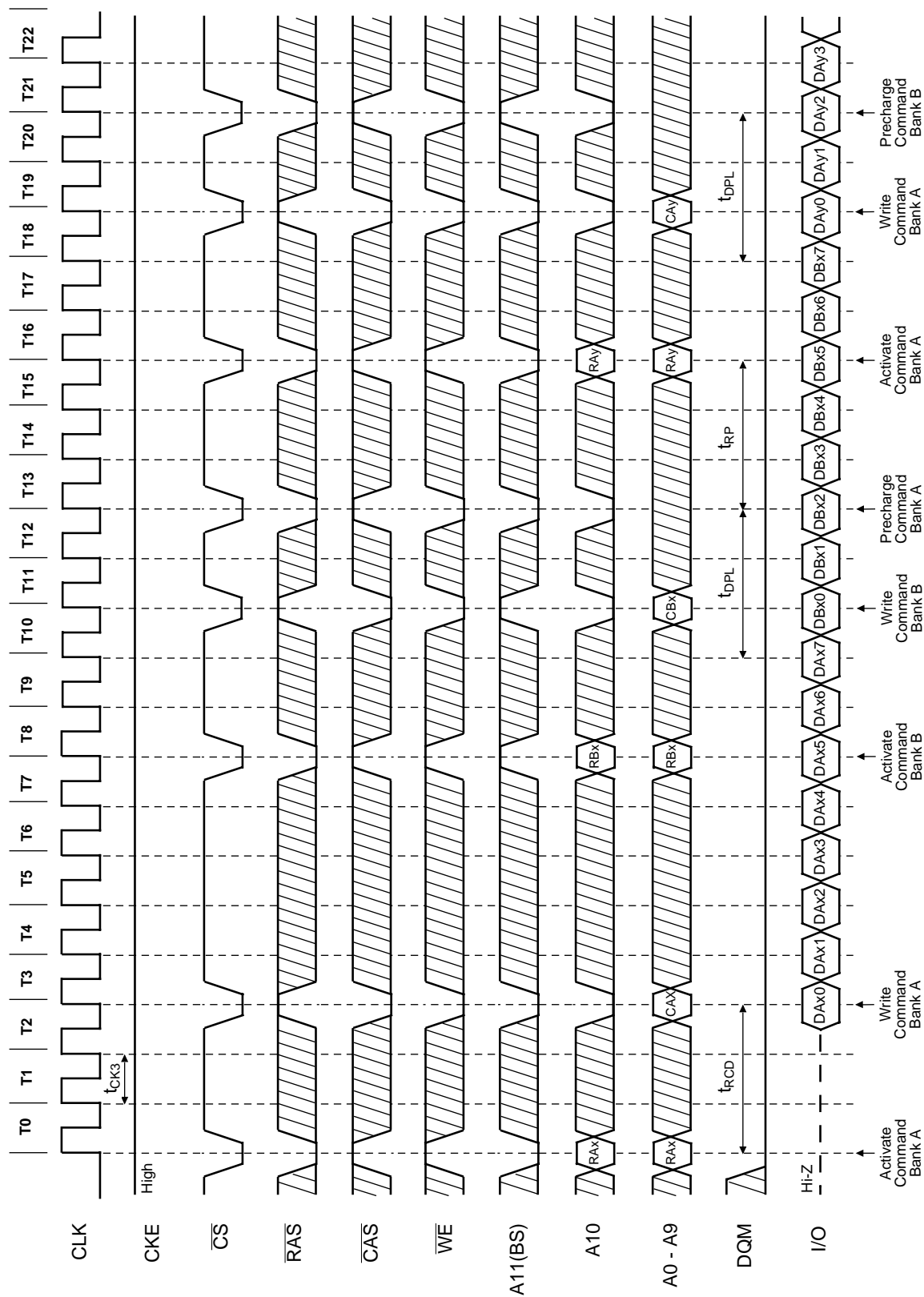

Burst Length = 8, CAS Latency = 2

19.1 Precharge Termination of a Burst (1 of 2)

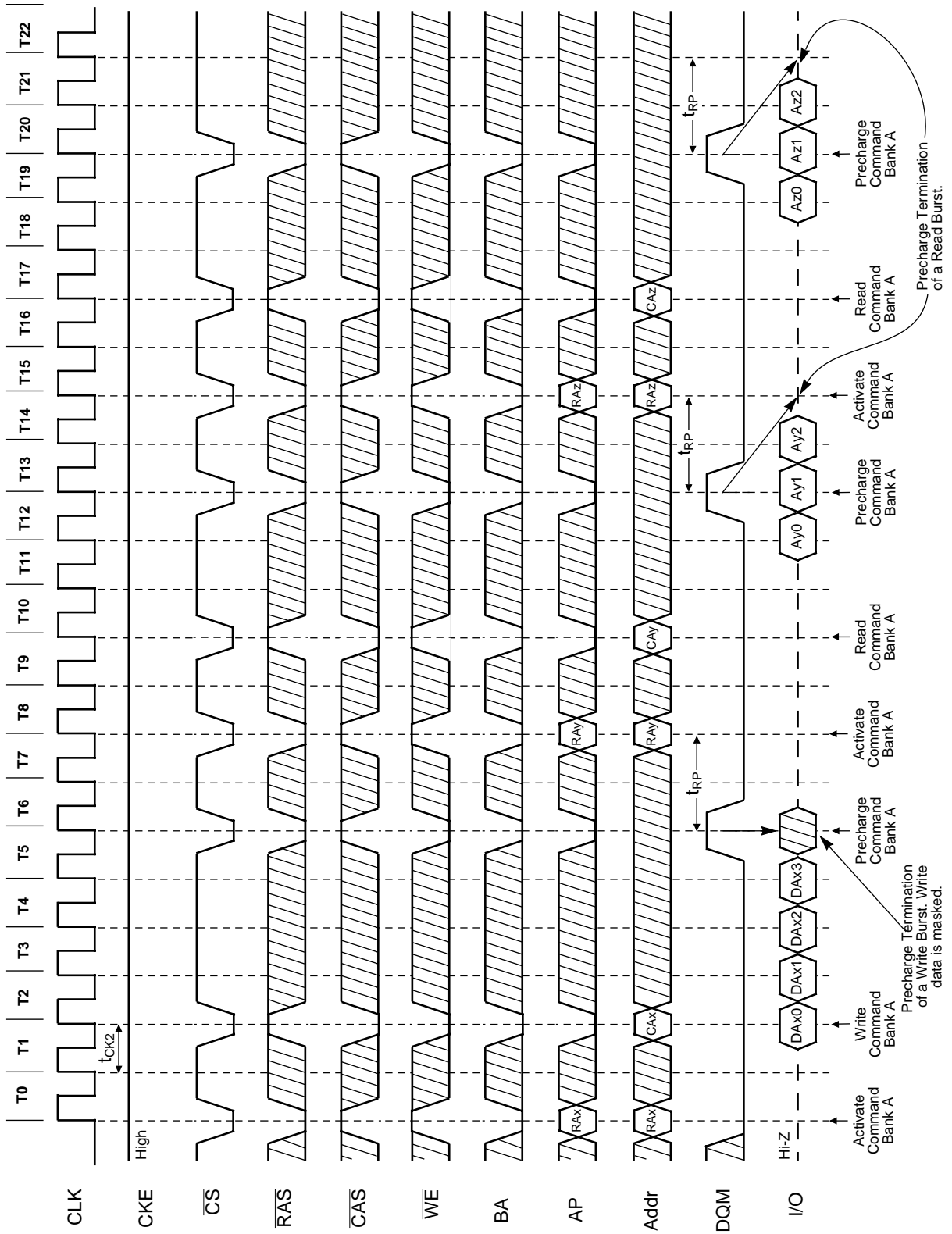

Burst Length = 4, 8, CAS Latency = 3

19.2 Precharge Termination of a Burst (2 of 2)

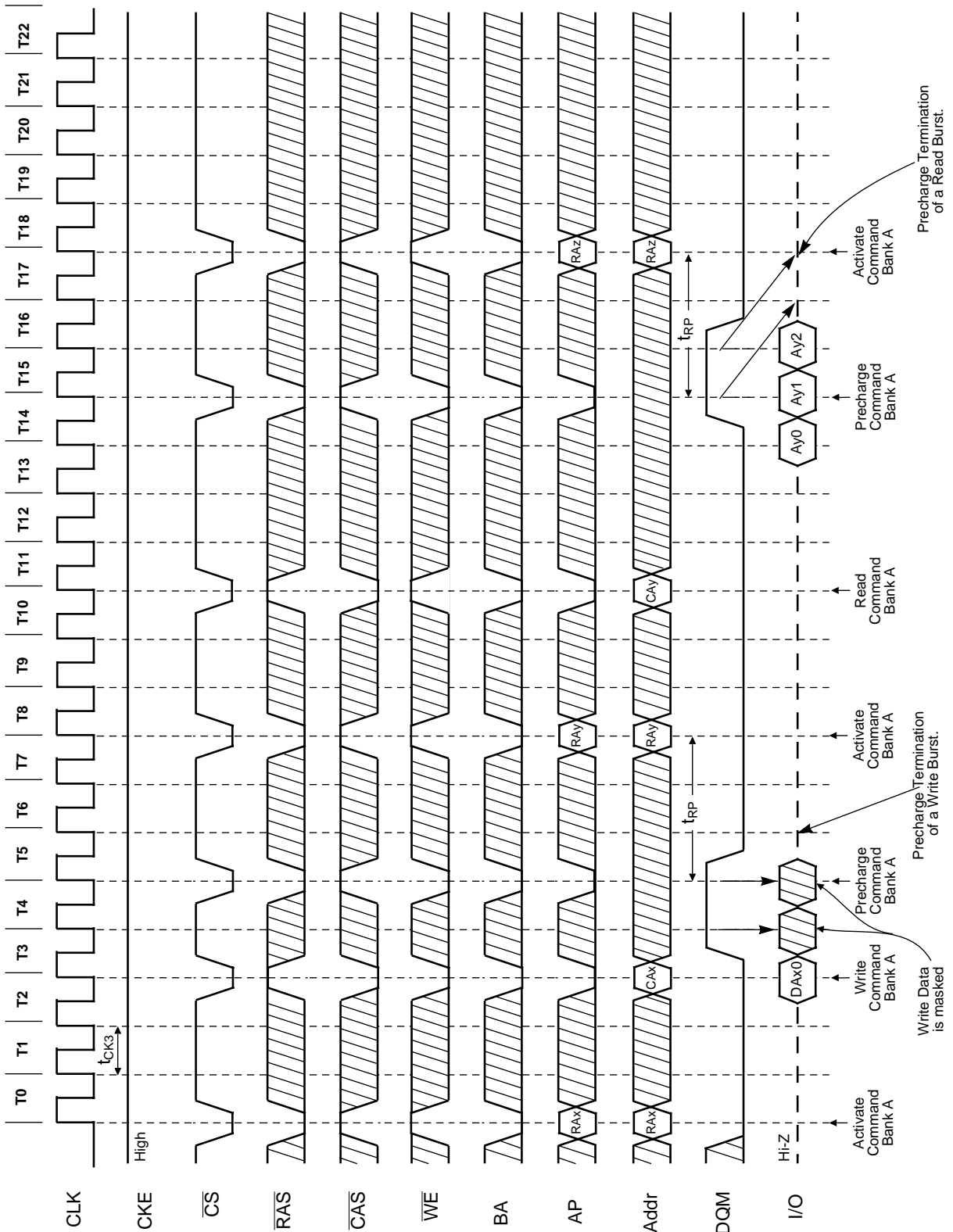

Deep Power Down Mode Entry

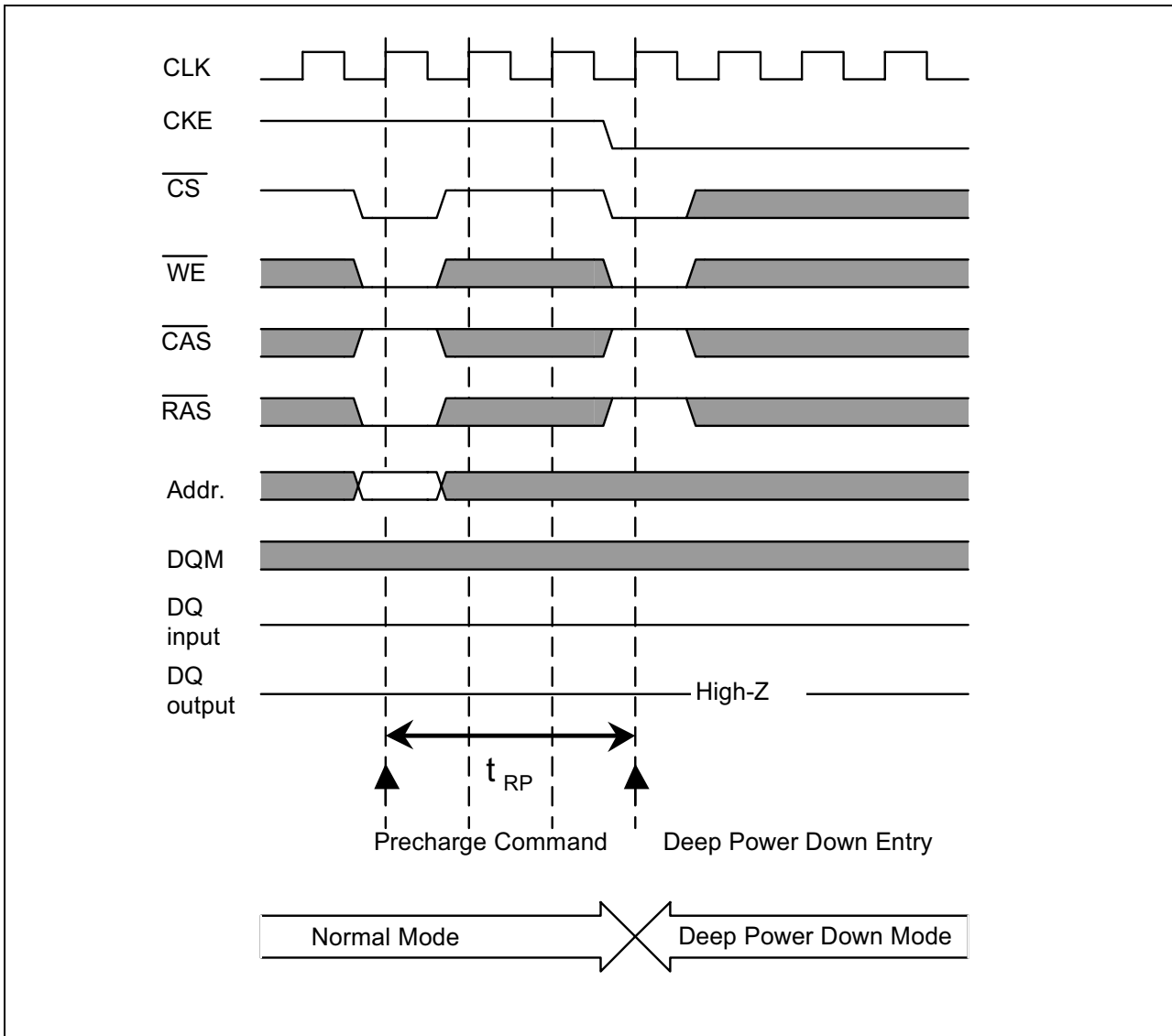

The deep power down mode has to be maintained for a minimum of 100µs.

Deep Power Down Exit

The deep power down mode is exited by asserting CKE high. After the exit, the following sequence is needed to enter a new command:

1. Maintain NOP input conditions for a minimum of 200 μ s
2. Issue precharge commands for all banks of the device
3. Issue eight or more autorefresh commands
4. Issue a mode register set command to initialize the mode register
5. Issue an extended mode register set command to initialize the extended mode register

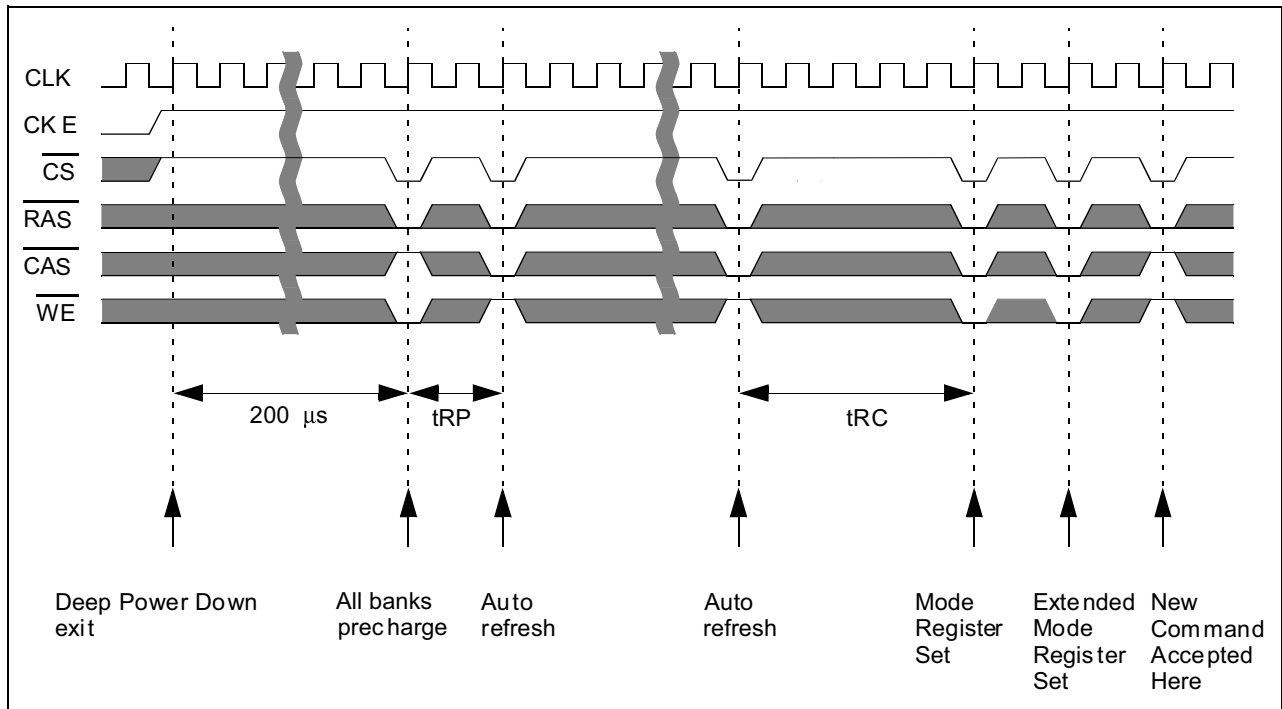

WORLDWIDE OFFICES**U.S.A.**

3910 NORTH FIRST STREET
SAN JOSE, CA 95134
PHONE: 408-433-6000
FAX: 408-433-0952

TAIWAN

7F, NO. 102
MIN-CHUAN E. ROAD, SEC. 3
TAIPEI
PHONE: 886-2-2545-1213
FAX: 886-2-2545-1209

NO 19 LI HSIN ROAD
SCIENCE BASED IND. PARK
HSIN CHU, TAIWAN, R.O.C.
PHONE: 886-3-579-5888
FAX: 886-3-566-5888

SINGAPORE

10 ANSON ROAD #23-13
INTERNATIONAL PLAZA
SINGAPORE 079903
PHONE: 65-6323-1801
FAX: 65-6323-7013

JAPAN

ONZE 1852 BUILDING 6F
2-14-6 SHINTOMI, CHUO-KU
TOKYO 104-0041
PHONE: 03-3537-1400
FAX: 03-3537-1402

UK & IRELAND

SUITE 50, GROVEWOOD
BUSINESS CENTRE
STRATHCLYDE BUSINESS
PARK
BELLSHILL, LANARKSHIRE,
SCOTLAND, ML4 3NQ
PHONE: 44-1698-748515
FAX: 44-1698-748516

U.S. SALES OFFICES**WEST**

3910 NORTH FIRST STREET
SAN JOSE, CA 95134
PHONE: 408-433-6000
FAX: 408-433-0952

CENTRAL / EAST

604 FIELDWOOD CIRCLE
RICHARDSON, TX 75081
PHONE: 214-352-3775
FAX: 214-904-9029

© Copyright , MOSEL VITELIC Corp.

Printed in U.S.A.

The information in this document is subject to change without notice.

MOSEL VITELIC makes no commitment to update or keep current the information contained in this document. No part of this document may be copied or reproduced in any form or by any means without the prior written consent of MOSEL-VITELIC.

MOSEL VITELIC subjects its products to normal quality control sampling techniques which are intended to provide an assurance of high quality products suitable for usual commercial applications. MOSEL VITELIC does not do testing appropriate to provide 100% product quality assurance and does not assume any liability for consequential or incidental arising from any use of its products. If such products are to be used in applications in which personal injury might occur from failure, purchaser must do its own quality assurance testing appropriate to such applications.
